



Instructions for Installation, Operation and Maintenance of Type DHP-VR Vacuum Replacement Circuit Breakers for DHP Switchgear

I.B. 6513C80G Supersedes I.B. 6513C80F dated November 2003
Effective March 2007



*DHP-VR™
5 kV Rating*

*DHP-VR™
7.5 and 15 kV Ratings*



**WARNING**

IMPROPERLY INSTALLING OR MAINTAINING THESE PRODUCTS CAN RESULT IN DEATH, SERIOUS PERSONAL INJURY OR PROPERTY DAMAGE.

READ AND UNDERSTAND THESE INSTRUCTIONS BEFORE ATTEMPTING ANY UNPACKING, ASSEMBLY, OPERATION OR MAINTENANCE OF THE CIRCUIT BREAKERS.

INSTALLATION OR MAINTENANCE SHOULD BE ATTEMPTED ONLY BY QUALIFIED PERSONNEL. THIS INSTRUCTION BOOK SHOULD NOT BE CONSIDERED ALL INCLUSIVE REGARDING INSTALLATION OR MAINTENANCE PROCEDURES. IF FURTHER INFORMATION IS REQUIRED, YOU SHOULD CONSULT CUTLER-HAMMER.

**WARNING**

THE CIRCUIT BREAKERS DESCRIBED IN THIS BOOK ARE DESIGNED AND TESTED TO OPERATE WITHIN THEIR NAMEPLATE RATINGS. OPERATION OUTSIDE OF THESE RATINGS MAY CAUSE THE EQUIPMENT TO FAIL, RESULTING IN DEATH, BODILY INJURY AND PROPERTY DAMAGE.

ALL SAFETY CODES, SAFETY STANDARDS AND/OR REGULATIONS AS THEY MAY BE APPLIED TO THIS TYPE OF EQUIPMENT MUST BE STRICTLY ADHERED TO.

THESE CIRCUIT BREAKER ELEMENTS ARE DESIGNED TO BE INSTALLED PURSUANT TO THE AMERICAN NATIONAL STANDARDS INSTITUTE (ANSI). SERIOUS INJURY, INCLUDING DEATH, CAN RESULT FROM FAILURE TO FOLLOW THE PROCEDURES OUTLINED IN THIS MANUAL. THESE CIRCUIT BREAKER ELEMENTS ARE SOLD PURSUANT TO A NON-STANDARD PURCHASING AGREEMENT WHICH LIMITS THE LIABILITY OF THE MANUFACTURER.

All possible contingencies which may arise during installation, operation or maintenance, and all details and variations of this equipment do not purport to be covered by these instructions. If further information is desired by purchaser regarding his particular installation, operation or maintenance of particular equipment, contact a Cutler-Hammer representative.

TABLE OF CONTENTS

PAGE

SECTION 1 INTRODUCTION

1-1 Available DHP-VR Breakers1

SECTION 2 SAFE PRACTICES5

SECTION 3 RECEIVING, HANDLING AND STORAGE

3-1 Receiving6
 3-2 Handling6
 3-3 Storage7
 3-4 DHP-VR Weights7

SECTION 4 INSTALLATION

4-1 Initial Inspection and Operation 12
 4-2 SURE CLOSE MECHANISM Adjustment 12
 4-3 Mechanism Operated Cell (MOC) Switch Pantograph Adjustment 14
 4-4 Manual Operation Check 15
 4-5 Vacuum Interrupter Integrity 15
 4-6 Insulation 15
 4-7 Contact Erosion and Wipe 15
 4-8 Primary Circuit Resistance 15
 4-9 Nameplate 15
 4-10 Snubber Adjustment 15
 4-11 Electrical Operations Check 15
 4-12 Lever Breaker Into Cell 18
 4-13 Removing Breaker From Cell 19

SECTION 5 DESCRIPTION AND OPERATION

5-1 Interrupter Assembly 20
 5-1.1 Vacuum Interrupter 21
 5-1.2 Contact Erosion Indicator 21
 5-1.3 "T" Cutout Loading Spring Indicator 21
 5-1.4 Contact Wipe and Stroke 21
 5-1.5 Phase Barriers 22
 5-2 Stored Energy Mechanism 22
 5-2.1 Operation of Stored Energy Mechanism 22
 5-2.2 Charging 22
 5-2.3 Closing Operation 22
 5-2.4 Tripping Operation 27
 5-2.5 Trip Free Operation 27
 5-3 Control Scheme 27
 5-3.1 Timing 27
 5-3.2 Secondary Disconnects 27

	PAGE
5-4 Interlocks	29
5-4.1 Breaker-Cell Coding Plates	29
5-4.2 Levering-in Interlock	29
5-4.3 Anti-Close Interlock	30
5-4.4 Floor Tripping and Closing Spring Release Interlocks	30
5-4.5 Rail Latch	30
5-5 Miscellaneous Items	32
5-5.1 Ground Contact	32
5-5.2 MOC and TOC Switch Operations	32
5-5.3 Operations Counter	32
5-6 Levering Device	32

SECTION 6 INSPECTION AND MAINTENANCE

6-1 Introduction	34
6-2 Frequency of Inspection	34
6-3 Inspection and Maintenance Procedures	35
6-4 Vacuum Interrupter Integrity Test	36
6-5 Contact Erosion and Wipe	36
6-6 Insulation	37
6-7 Insulation Integrity Check	37
6-8 Primary Circuit Resistance Check	38
6-9 Mechanism Check	38
6-9.1 CloSure™ Test	39
6-10 Lubrication	43
6-11 Troubleshooting	44

SECTION 7 RENEWAL PARTS

7-1 General	47
7-1.1 Ordering Instructions	47

TABLES

Table	Title	Page
1.1	Type DHP-VR™ Vacuum Circuit Breaker Availability and Interchangeability	1
3.1	DHP-VR Weights	7
5.1	Typical Opening and Closing Times	27
6.1	Vacuum Interrupter Integrity Test Voltage	36
6.4	CloSure™ Tool Mounting/Testing Locations by Circuit Breaker Type	43

FIGURES

Table	Title	Page
1-1	Outline and Dimensions (inches) Type DHP-VR Breakers (5 kV, 250 MVA Rating)	2
1-2	Outline and Dimensions (inches) Type DHP-VR Breakers (5 kV, 350 MVA Rating)	3
1-3	Outline and Dimensions (inches) Type DHP-VR Breakers (7.5 kV and 15 kV Ratings)	4
3-1	Typical DHP-VR Tools and Accessories	6
3-2	Front External View of DHP-VR Breaker (5 kV, 250 MVA Rating)	8
3-3	Rear External View of DHP-VR Breaker (5 kV, 250 MVA Rating)	9
3-4	Front External View of DHP-VR Breaker (7.5 and 15 kV, 500 and 750 MVA Ratings)	10
3-5	Rear External View of DHP-VR Breaker (7.5 and 15 kV, 500 and 750 MVA Ratings)	11

	Page
4-1	MOC Drive Spring 13
4-2	Drive Spring Adjusted for 0 to 1 MOC Switch..... 13
4-3	Drive Spring Adjustment Graphic 13
4-4	Checking Drive Spring for Proper Adjustment for One Installed Moc Switch 13
4-5	Drive Spring Shown Adjusted for 2 MOC Switches 14
4-6a	Drive Spring Shown Adjusted for 3 MOC Switches 14
4-6b	5 kV Drive Spring Adjusted for 3 MOC Switches 14
4-7	MOC Pantograph Adjustment 14
4-8	Snubber Adjustment 16
4-9	Positioning of 5 kV DHP-VR Breaker..... 17
4-10	Positioning of 7.5 or 15 kV DHP-VR Breaker 18
4-11	Final Engagement of 5 kV Secondary Contact..... 18
4-12	Final Engagement of 7.5 or 15 kV Secondary Contact 18
4-13	Levering 5 kV Breaker to Connected Position 19
4-14	Levering 7.5 or 15 kV Breaker to Connected Position 19
5-1	DHP-VR 5 kV Interrupter Assembly 20
5-2	DHP-VR 7.5 or 15 kV Interrupter Assembly 20
5-3	DHP-VR 5 kV Design - Front Faceplate Removed..... 23
5-4	DHP-VR 7.5 or 15 kV Design - Front Faceplate Removed 24
5-5	Closing Cam and Trip Linkage 25
5-6	Charging Schematic 26
5-7	Typical DHP-VR "DC" and "AC" Control Schemes 28
5-8	Male Secondary Contact Block (In Extended Position) On 5 kV DHP-VR Breaker 29
5-9	Male Secondary Contact Block (In Extended Position) On 15 kV DHP-VR Breaker 29
5-10	Code Plate Installed On 5 kV DHP-VR Breaker 30
5-11	Code Plate Installed On 15 kV DHP-VR Breaker 30
5-12	DHP-VR Breaker (5 kV) Floor Tripping Levers (Underneath Front View) 31
5-13	DHP-VR Breaker (7.5 or 15 kV) Floor Tripping Lever (Underneath Rear View) 31
5-14	DHP-VR Breaker (5 kV) Rail Latch 31
5-15	DHP-VR Breaker (7.5 or 15 kV) Rail Latch 31
5-16	DHP-VR Breaker Ground Contact..... 32
5-17	DHP-VR Breaker (5 kV) Levering-in Device Nut Housing 33
5-18	DHP-VR Breaker (7.5 or 15 kV) Levering-in Device Nut Housing 33
6-1	Lubrication Points 34
6-2	Vacuum Interrupter Showing Contact Erosion Indicator with Breaker Open 37
6-3	Vacuum Interrupter Showing Contact Erosion Indicator with Breaker Closed 37
6-4	"T" Contact Wipe Indicator Example with Blue Spring 38
6-5	Wipe Indication Procedure 38
6-6	Status Indicators..... 39
6-7	Starting Tape at Bottom of Cam 39
6-8	Wrapping Tape up around Cam 40
6-9	Attaching Tape around to Back of Cam..... 40
6-10	Attaching CloSure™ Test Tool at Hole "A" 40
6-11	Attaching CloSure™ Test Tool at Hole "B" 41
6-12	Manually Charging Closing Springs 41
6-13	Manually Closing Circuit Breaker with Marker in Hole "C" 41
6-14	Top View of Cam and Marker Interface 41
6-15	Move Marker 15° to right 41
6-16	Move Marker 15° to left 42
6-17	Remove Marker Masking Tape from Cam 42
6-18	Place Tape on Right Side Panel of Breaker 42
6-19	Illustrative Testing Tape Sample 42
6-20	Front View of CloSure™ Tool Showing Mounting/Testing Hole Locations 42
6-21	Typical Circuit Breaker Front View with CloSure™ Tool Attached 43

SECTION 1: INTRODUCTION

The purpose of this book is to provide instructions for unpacking, storage, installation, operation and maintenance of Type DHP-VR Vacuum Replacement Circuit Breakers. They are horizontal draw out type removable interrupting elements for use in existing DHP Metal-Clad Switchgear. DHP-VR Circuit Breakers provide reliable control, protection and performance, with ease of handling and maintenance. Like ratings are interchangeable with each other.

1-1 AVAILABLE DHP-VR BREAKERS

Refer to Table 1.1.



WARNING

SATISFACTORY PERFORMANCE OF THESE BREAKERS IS CONTINGENT UPON PROPER APPLICATION, CORRECT INSTALLATION AND ADEQUATE MAINTENANCE. THIS INSTRUCTION BOOK MUST BE CAREFULLY READ AND FOLLOWED IN ORDER TO OBTAIN OPTIMUM PERFORMANCE FOR LONG USEFUL LIFE OF THE CIRCUIT BREAKERS.

TYPE DHP-VR BREAKERS ARE PROTECTIVE DEVICES, AS SUCH, THEY ARE MAXIMUM RATED DEVICES. THEREFORE, THEY SHOULD NOT UNDER ANY CIRCUMSTANCE BE APPLIED OUTSIDE THEIR NAMEPLATE RATINGS.

Table 1.1 DHP-VR™ Vacuum Circuit Breaker Availability and Interchangeability

Nominal Voltage Class (kV)	Existing DHP™ or DVP™ Breaker Type	Rated Continuous Current at 60 Hz (Amps)	DHP-VR™ Replacement Breaker Type	Rated Continuous Current at 60 Hz (Amps)	Rated Voltage Factor K	Rated Withstand Test Voltage		Rated ④ Short-Circuit Current kA RMS	Maximum ⑤ Sym. Interrupting Capability kA RMS	Closing and Latching Capability kA RMS/Crest
						Low Freq. kV RMS	Impulse kV Crest			
4.16	50DHP250	1200	50DHP-VR250	1200	1.24	19	60	29	36	58/97
4.16	50DHP250	2000	50DHP-VR250	2000	1.24	19	60	29	36	58/97
4.16	H50DHP250	1200	50DHP-VR250H	1200	1.24	19	60	29	36	78/132
4.16	H50DHP250	2000	50DHP-VR250H	2000	1.24	19	60	29	36	78/132
4.16	XX	1200	50DHP-VR250U	1200	1.19	19	60	41	49	78/132
4.16	XX	2000	50DHP-VR250U	2000	1.19	19	60	41	49	78/132
4.16	50DHP350	1200	50DHP-VR350	1200	1.19	19	60	41	49	78/132
4.16	50DHP350	2000	50DHP-VR350	2000	1.19	19	60	41	49	78/132
7.2	75DHP500	1200	75DHP-VR500	1200	1.25	36	95	33	41	66/111
7.2	75DHP500	2000	75DHP-VR500	2000	1.25	36	95	33	41	66/111
7.2	75DVP500	1200	75DHP-VR500	1200	1.25	36	95	33	41	66/111
7.2	75DVP500	2000	75DHP-VR500	2000	1.25	36	95	33	41	66/111
13.8	150DHP500	1200	150DHP-VR500	1200	1.30	36	95	18	23	37/62
13.8	150DHP500	2000	150DHP-VR500	2000	1.30	36	95	18	23	37/62
13.8	150DVP500	1200	150DHP-VR500	1200	1.30	36	95	18	23	37/62
13.8	150DVP500	2000	150DHP-VR500	2000	1.30	36	95	18	23	37/62
13.8	H150DHP500	1200	150DHP-VR500H	1200	1.30	36	95	18	23	58/97
13.8	H150DHP500	2000	150DHP-VR500H	2000	1.30	36	95	18	23	58/97
13.8	150DHP750	1200	150DHP-VR750	1200	1.30	36	95	28	36	58/97
13.8	150DHP750	2000	150DHP-VR750	2000	1.30	36	95	28	36	58/97
13.8	150DHP750C	1200	150DHP-VR750C	1200	1.30	36	95	28	36	58/97
13.8	150DHP750C	2000	150DHP-VR750C	2000	1.30	36	95	28	36	58/97
13.8	150DVP750	1200	150DHP-VR750	1200	1.30	36	95	28	36	58/97
13.8	150DVP750	2000	150DHP-VR750	2000	1.30	36	95	28	36	58/97
13.8	H150DHP750	1200	150DHP-VR750H	1200	1.30	36	95	28	36	77/130
13.8	H150DHP750	2000	150DHP-VR750H	2000	1.30	36	95	28	36	77/130
13.8	H150DHP750C	1200	150DHP-VR750CH	1200	1.30	36	95	28	36	77/130
13.8	H150DHP750C	2000	150DHP-VR750CH	2000	1.30	36	95	28	36	77/130
13.8	150DHP1000	1200	150DHP-VR1000	1200	1.30	36	95	37	48	77/130
13.8	150DHP1000	2000	150DHP-VR1000	2000	1.30	36	95	37	48	77/130

- ① Published DHP-VR™ Vacuum Circuit Breaker ratings are per current revision of ANSI C37.06 (symmetrical current basis)
- ② Existing breaker rated per ANSI C37.06-1961 Table 2 (total current basis).
- ③ Existing breaker rated post ANSI C37.06-1 964 (symmetrical current basis).

- ④ At rated maximum kV.
- ⑤ K times rated short circuit current (KI).
- xx 50DHP250 enclosures must be updated to be compatible with 50DHP-VR250U ratings

Rating	A	B	C	D
250	22.40	21.88	48.76	24.03
250U	22.40	21.88	48.76	24.03

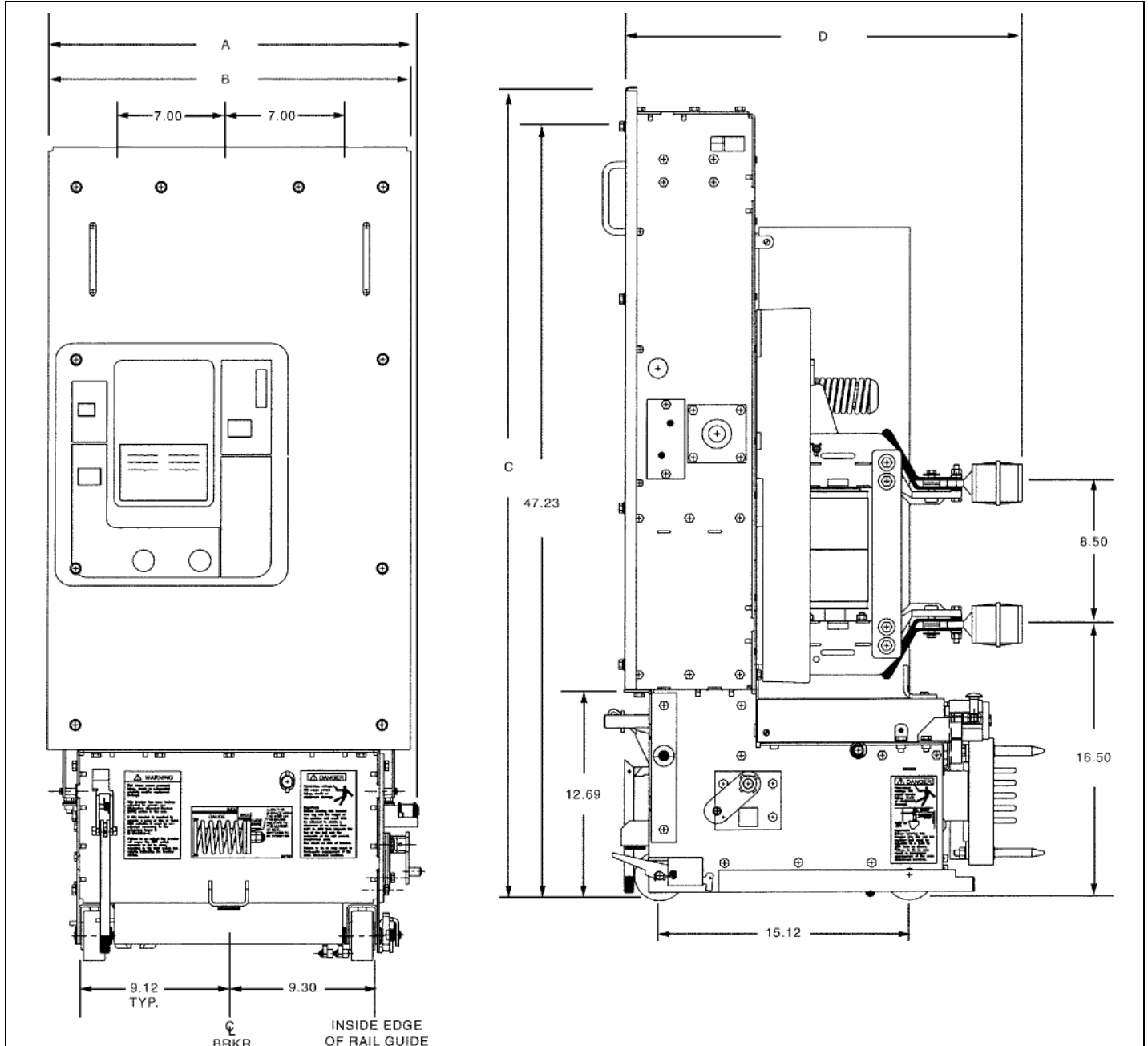

Figure 1-1 Outline and Dimensions (inches) Type DHP-VR Breakers (5 kV, 250 MVA Rating)

Rating	A	B	C	D
350	22.65	22.38	57.16	29.38

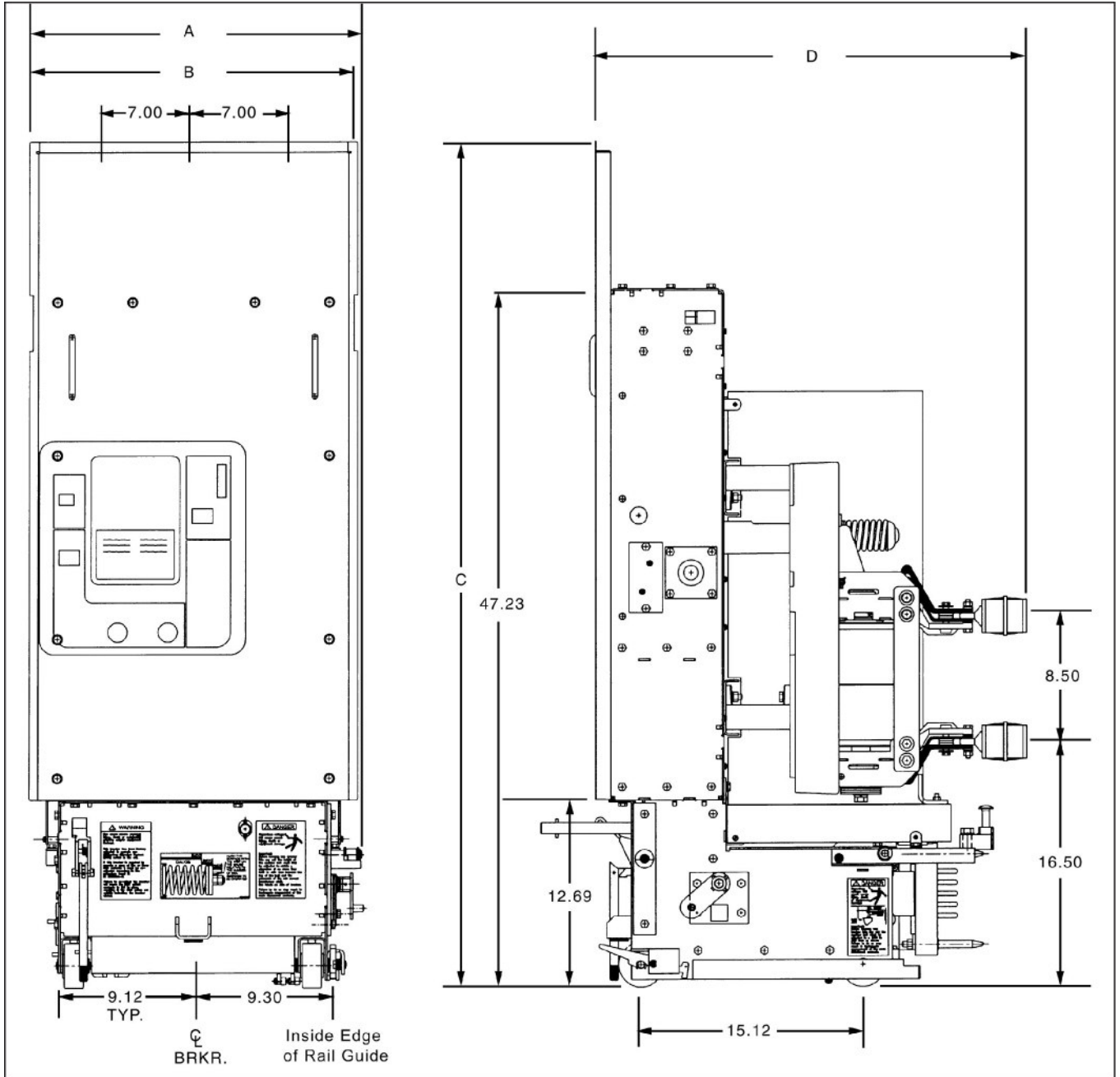

Figure 1-2 Outline and Dimensions (inches) Type DHP-VR Breakers (5 kV, 350 MVA Rating)

Rating	A	B	C
500	60.75	31.25	34.81
750	60.75	31.25	34.81
750C	73.75	31.00	38.35
1000	73.75	31.00	38.35

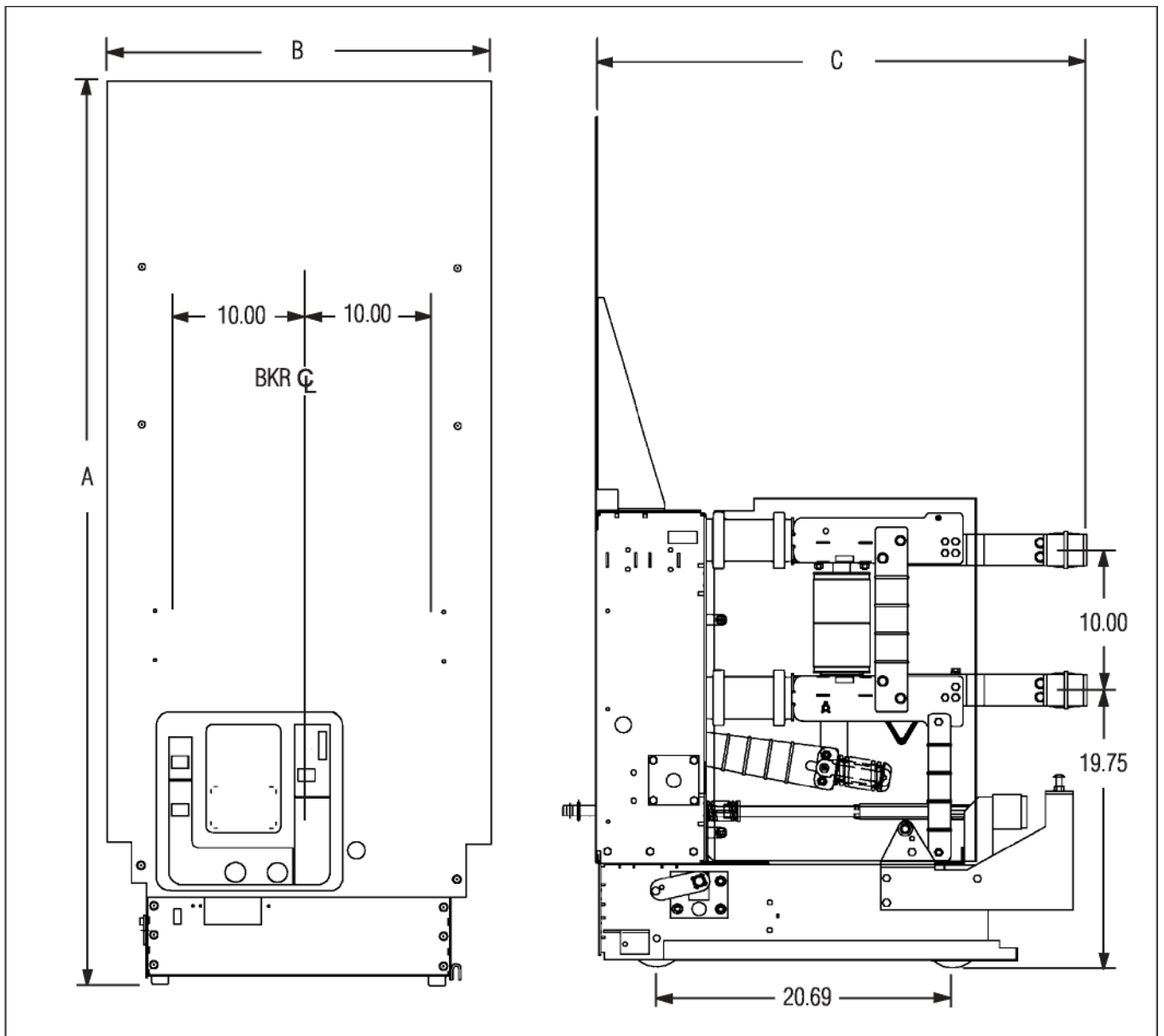

Figure 1-3 Outline and Dimensions (inches) Type DHP-VR Breakers (7.5 kV and 15 kV Ratings)

SECTION 2: SAFE PRACTICES

Type DHP-VR breakers are equipped with high speed, high energy operating mechanisms. They are designed with several built-in interlocks and safety features to provide safe and proper operating sequences.



WARNING

TO PROTECT THE PERSONNEL ASSOCIATED WITH INSTALLATION, OPERATION, AND MAINTENANCE OF THESE BREAKERS, THE FOLLOWING PRACTICES MUST BE FOLLOWED:

- Only qualified persons, as defined in the National Electrical Safety Code, who are familiar with the installation and maintenance of medium voltage circuits and equipment, should be permitted to work on these breakers.
- Read these instructions carefully before attempting any installation, operation or maintenance of these breakers.
- Always remove the breaker from the enclosure before performing any maintenance. Failure to do so could result in electrical shock leading to death, severe personal injury or property damage.
- Do not work on a breaker with the secondary test coupler engaged. Failure to disconnect the test coupler could result in an electrical shock leading to death, personal injury or property damage.

- Do not work on a closed breaker or a breaker with closing springs charged. The closing spring should be discharged and the main contacts open before working on the breaker. Failure to do so could result in cutting or crushing injuries.
- Do not use a circuit breaker by itself as the sole means of isolating a high voltage circuit. Remove the breaker to the Disconnect position and follow all lock-out and tagging rules of the National Electrical Code and any and all applicable codes, regulations and work rules.
- Do not leave the breaker in an intermediate position in the cell. Always have the breaker either in the Test or Connected position. Failure to do so could result in a flash over and possible death, personal injury or property damage.
- Always remove the maintenance tool from the breaker after charging the closing springs.
- Breakers are equipped with safety interlocks. Do not defeat them. This may result in death, bodily injury or equipment damage.

SECTION 3: RECEIVING, HANDLING AND STORAGE

Type DHP-VR circuit breakers are subjected to complete factory production tests and inspection before being packed. They are shipped in packages designed to provide maximum protection to the equipment during shipment and storage and at the same time to provide convenient handling. Accessories such as the maintenance tool, levering crank, etc. are shipped separately (Figure 3-1).

3-1 RECEIVING

Until the breaker is ready to be delivered to the switchgear site for installation, DO NOT remove it from the wooden crate. If the breaker is to be placed in storage, maximum protection can be obtained by keeping it in its crate.

Upon receipt of the equipment, inspect the crates for any signs of damage or rough handling. Open the crates carefully to avoid any damage to the contents. Use a nail puller rather than a crow bar when required.

When opening the crates, be careful that any loose items or hardware are not discarded with the packing material. Check the contents of each package against the packing list.

Examine the breaker for any signs of shipping damage such as broken, missing or loose hardware, damaged or deformed insulation and other components. File claims immediately with the carrier if damage or loss is detected and notify the nearest Cutler-hammer Sales Office.

Tools and Accessories

Maintenance Tool: Used to charge the closing springs. (Style 8064A02G01)

Levering Crank: Used to crank the breaker between Test and Connected positions. (Style 509A931G01)

Lifting Yoke: Optional item used to lift the breaker.
5kV. DHP-VR (Style 691 C607G03)
7.5/15kV. DH P-VR (Style 691 C607G01)

Turning Dolly: Optional item used to help maneuver breaker when out of structure. (Style 677C889G01)

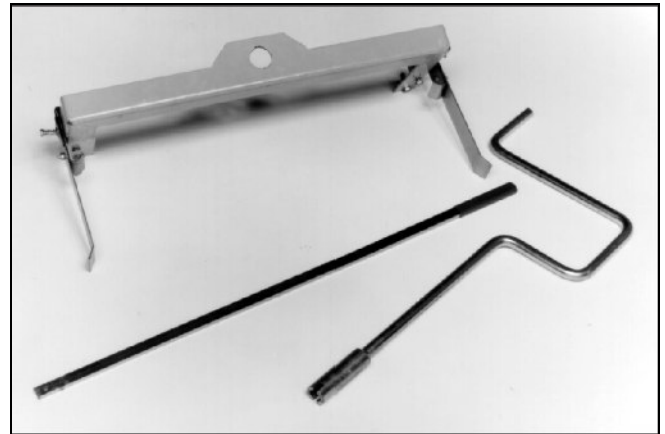

Figure 3-1 Typical DHP-VR Tools and Accessories

3-2 HANDLING



WARNING

DO NOT USE ANY LIFTING DEVICE AS A PLATFORM FOR PERFORMING MAINTENANCE, REPAIR OR ADJUSTMENT OF THE BREAKER OR FOR OPENING, CLOSING THE CONTACTS OR CHARGING THE SPRINGS. THE BREAKER MAY SLIP OR FALL CAUSING SEVERE PERSONAL INJURY. ALWAYS PERFORM MAINTENANCE, REPAIR AND ADJUSTMENTS ON A WORKBENCH CAPABLE OF SUPPORTING THE BREAKER.

Type DHP-VR breaker shipping containers are designed to be handled either by use of a rope sling and overhead lifting device or by a fork lift truck. If containers must be skidded for any distance, it is preferable to use roller conveyors or individual pipe rollers.

Once a breaker has been inspected for shipping damage, it is best to return it to its original shipping crate until it is ready to be installed in the Metal-Clad Switchgear.

When a breaker is ready for installation, a lifting yoke, in conjunction with an overhead lifter or portable floor lifter, can be used to move a breaker. If this is preferable to rolling the breaker on the floor using self contained wheels. If the breaker is to be lifted, position the lifting yoke over the breaker and insert lifters into the breaker side openings, with the lifting hole toward the interrupters.

Once the lifting yoke is securely seated in the lifting holes, the breaker can be carefully lifted and moved. Keep in mind, however, the faceplate on all 7.5 or 15 kV. DHP-VR breakers must be removed to use a lifting yoke.

3-3 STORAGE

If the circuit breaker is to be placed in storage, maximum protection can be obtained by keeping it in the original wooden crate. Before placing it in storage, checks should be made to make sure that the breaker is free from shipping damage and is in satisfactory operating condition.

The breaker is shipped with its contacts open and closing springs discharged. The indicators on the front panel should confirm this. Insert the maintenance tool in the manual charge socket opening (Figure 3-2 or 3-4). Charge the closing springs by pumping the handle up and down about 36 times until a crisp metallic "click" is heard. This indicates that the closing springs are charged and is shown by the closing spring "charged" (yellow) indicator. Remove the maintenance tool. Push the "manual close" button. The breaker will close as shown by the breaker contacts "closed" (red) indicator. Push the "manual trip" button. The breaker will trip as shown by the breaker contacts "open" (green) indicator. After completing this initial check, leave the closing springs discharged and breaker contacts open.

Outdoor storage is **NOT** recommended. If unavoidable, the outdoor location must be well drained and a temporary shelter from sun, rain, snow, corrosive fumes, dust, dirt falling objects, excessive moisture, etc. must be provided. Containers should be arranged to permit free circulation of air on all sides and temporary heaters should be used to minimize condensation. Moisture can cause rusting of metal parts and deterioration of high voltage insulation. A heat level of approximately 400 watts for each 100 cubic feet of volume is recommended with the heaters distributed uniformly throughout the structure near the floor.

Indoor storage should be in a building with sufficient heat and circulation to prevent condensation. If the building is not heated, the same general rule for heat as for outdoor storage should be applied.

3-4 DHP-VR WEIGHTS

Refer to Table 3.1.

Table 3.1

Circuit Breaker Type	Amperes	LBs.
50DHP-VR250	1200	435
50DHP-VR250	2000	510
50DHP-VR250U	1200	480
50DHP-VR250U	2000	510
50DHP-VR350	1200	495
50DHP-VR350	2000	525
75DHP-VR500	1200	510
75DHP-VR500	2000	565
150DHP-VR500	1200	480
150DHP-VR500	2000	565
H150DHP-VR500	1200	485
H150DHP-VR500	2000	565
150DHP-VR750	1200	485
150DHP-VR750	2000	565
150DHP-VR750C	1200	515
150DHP-VR750C	2000	595
150DHP-VR1000	1200	575
150DHP-VR1000	2000	600

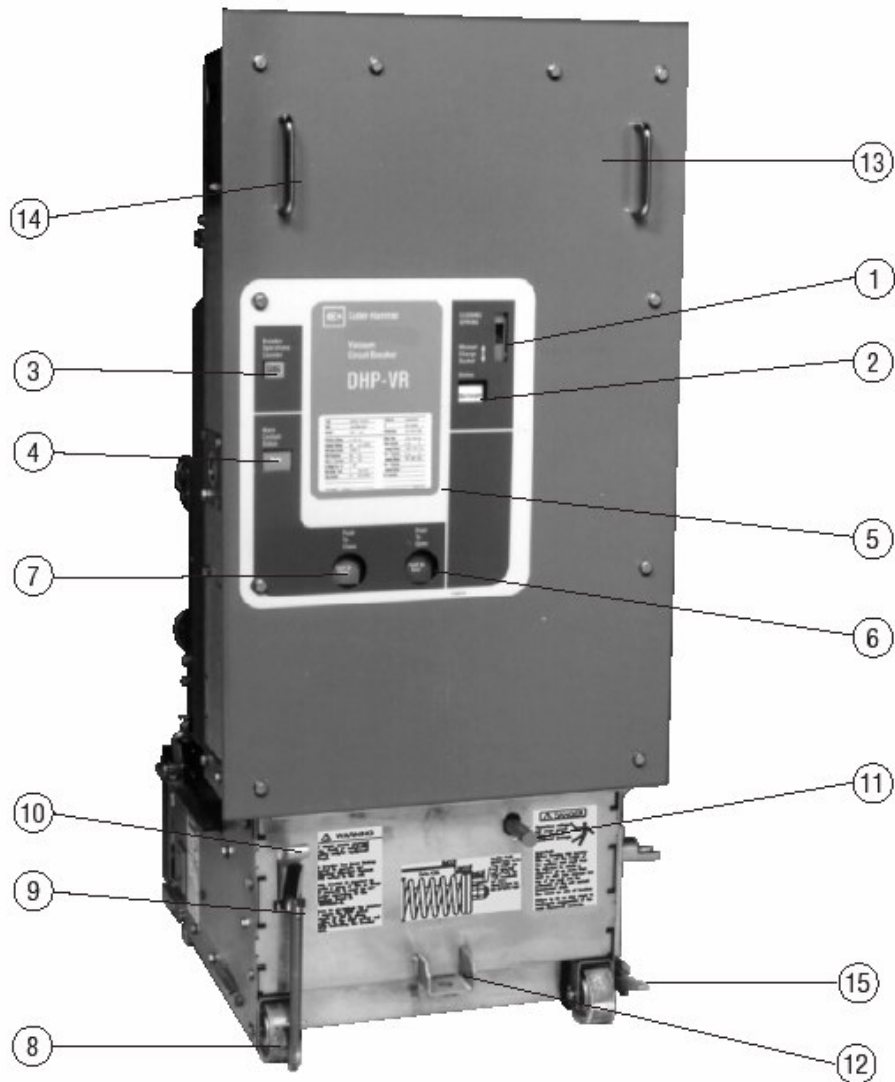

- | | |
|---------------------------------------|-----------------------------------|
| ① Manual Charge Socket | ⑧ Breaker Wheel |
| ② Spring Charged/Discharged Indicator | ⑨ Secondary Contact Operating Rod |
| ③ Operation Counter | ⑩ Secondary Contact Handle |
| ④ Breaker Contacts Indicator | ⑪ Levering-in Operating Shaft |
| ⑤ Nameplate | ⑫ Turning Dolly Bracket |
| ⑥ Push To Trip Button | ⑬ Removable Faceplate |
| ⑦ Push To Close Button | ⑭ Pull/Push Handle |
| | ⑮ Rail Latch |

Figure 3-2 Front External View of DHP-VR Breaker (5kV, 250 MVA Rating)

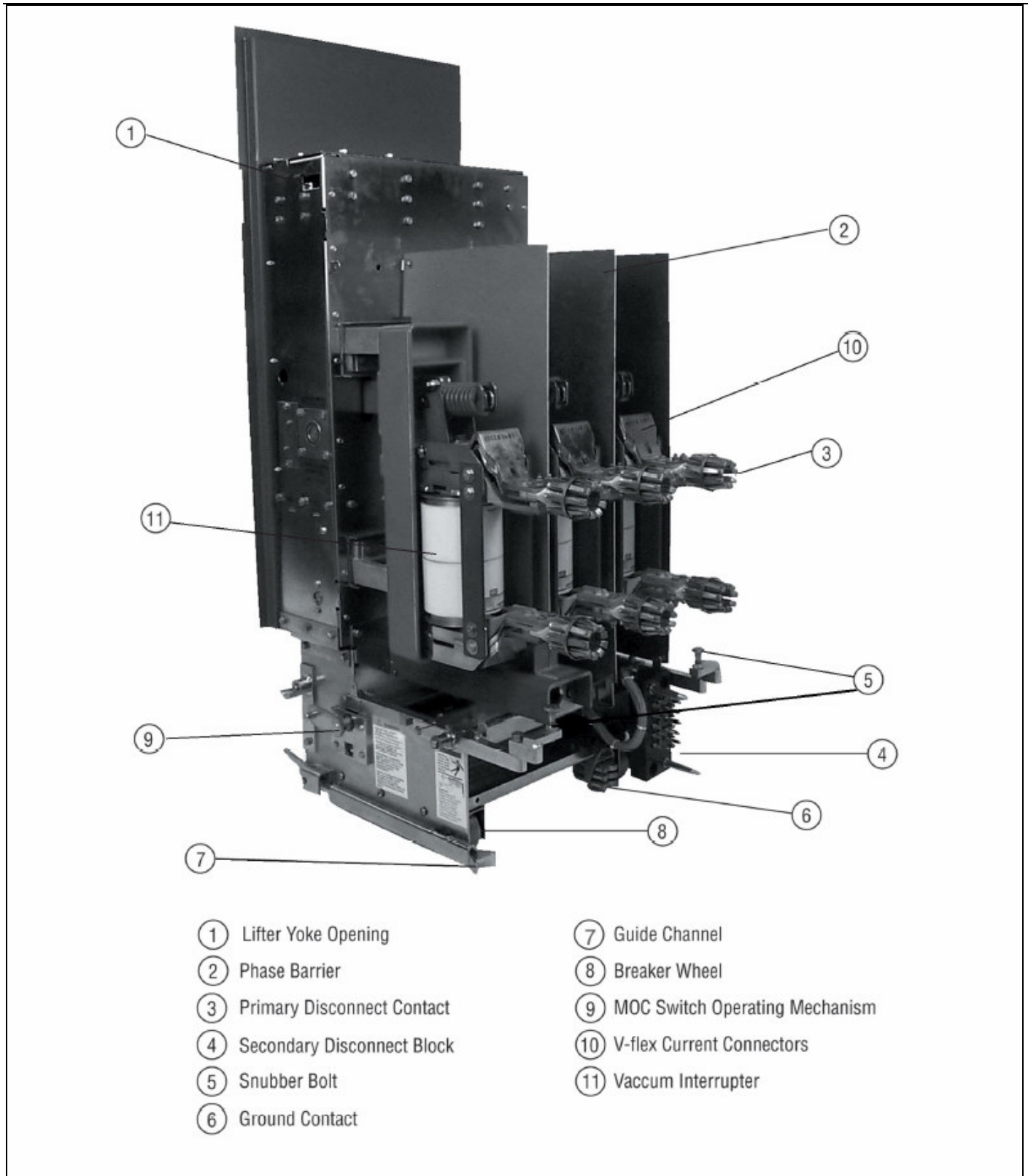
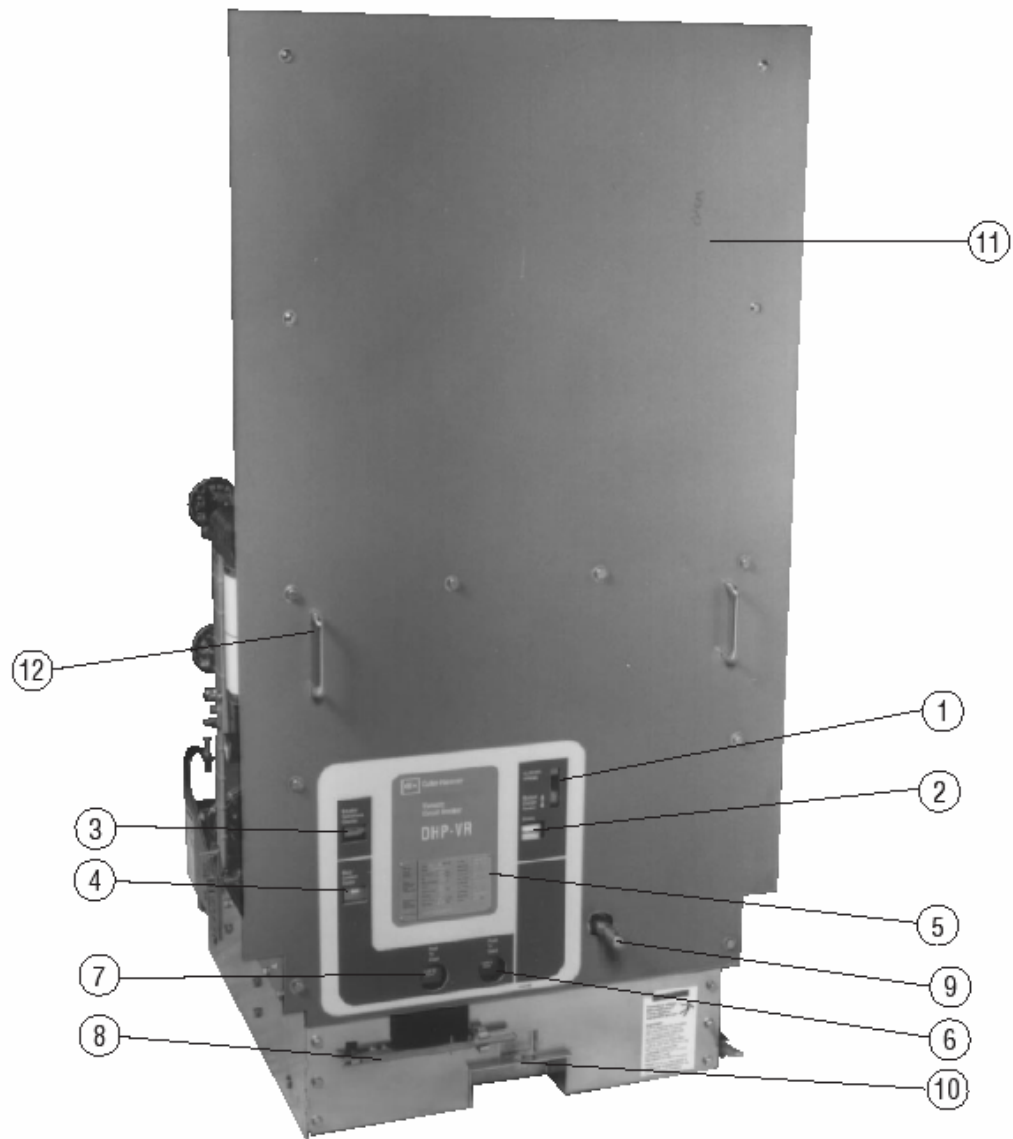

Figure 3-3 Rear External View of DHP-VR Breaker (5 kV, 350 MVA Rating)



- | | |
|---------------------------------------|-------------------------------|
| ① Manual Charge Socket | ⑦ Push To Close Button |
| ② Spring Charged/Discharged Indicator | ⑧ Secondary Engaging Handle |
| ③ Operation Counter | ⑨ Levering-in Operating Shaft |
| ④ Breaker Contacts Indicator | ⑩ Turning Dolly Bracket |
| ⑤ Nameplate | ⑪ Removable Faceplate |
| ⑥ Push To Trip Button | ⑫ Pull/Push Handle |

Figure 3-4 Front External View of DHP-VR Breaker (7.5 and 15 kV, 500 and 750 MVA Ratings)

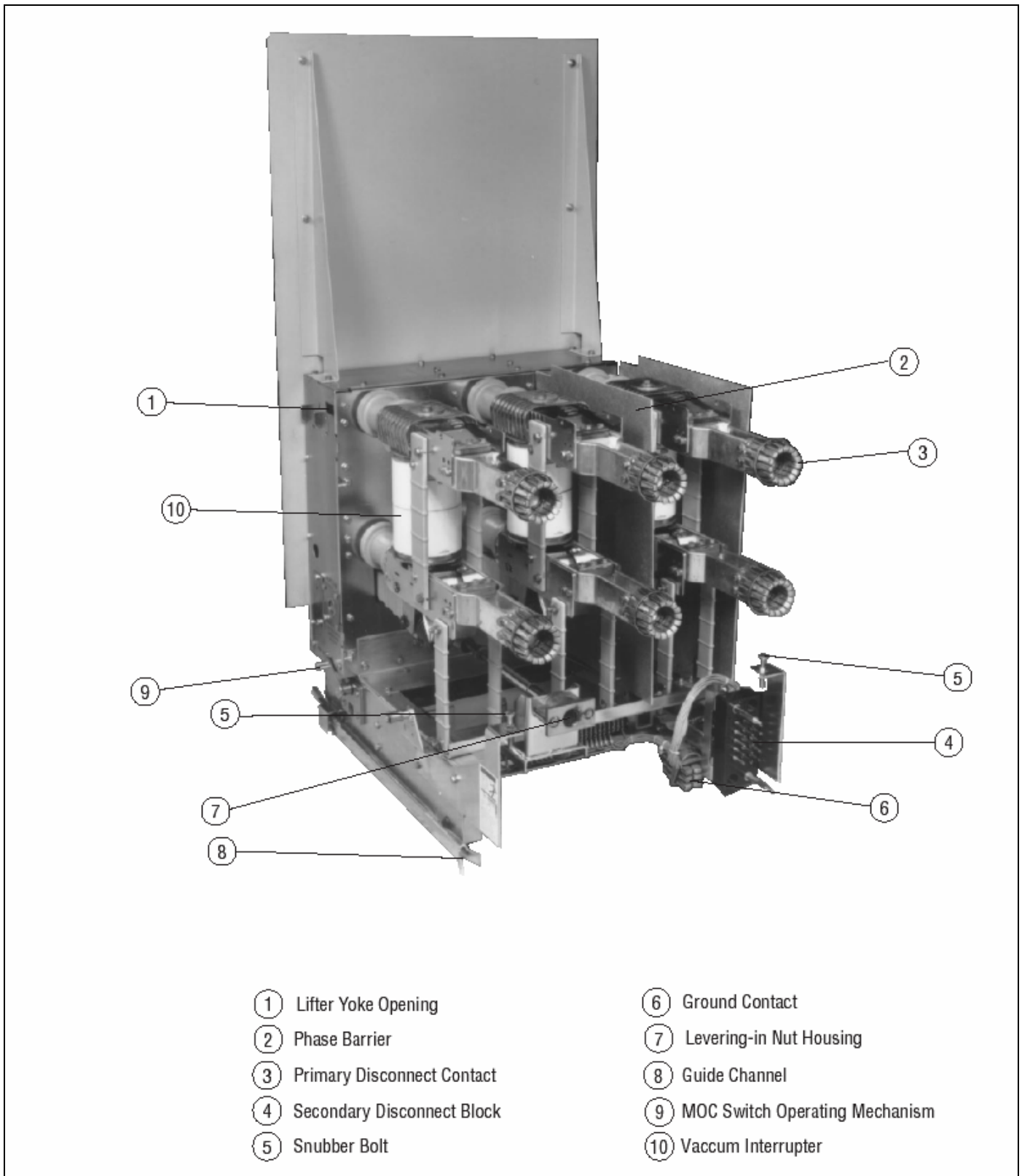

Figure 3-5 Rear External View of DHP-VR Breaker (7.5 and 15 kV, 500 and 750 MVA Ratings)

SECTION 4: INSTALLATION



WARNING

BEFORE PLACING THE BREAKER IN SERVICE, CAREFULLY FOLLOW THE INSTALLATION PROCEDURE GIVEN BELOW. NOT FOLLOWING THE PROCEDURE CAN FAIL TO UNCOVER SHIPPING DAMAGE THAT MAY RESULT IN INCORRECT BREAKER OPERATION LEADING TO DEATH, BODILY INJURY, AND PROPERTY DAMAGE.

4-1 INITIAL INSPECTION AND OPERATION

Before attempting to put the breaker in service, it should be carefully examined and operated manually and electrically.

Examine a breaker for loose or obviously damaged parts.

4-2 SURE CLOSE MECHANISM ADJUSTMENT



WARNING

FOR ALL TYPE DHP 15 KV HOUSINGS EQUIPPED WITH MECHANISM OPERATED CELL (MOC) SWITCHES, THE STEPS OUTLINED IN THIS PARAGRAPH MUST BE PERFORMED BEFORE INSTALLING A REPLACEMENT DHP-VR CIRCUIT BREAKER. FAILURE TO COMPLY COULD CAUSE SEVERE PERSONAL INJURY, DEATH, EQUIPMENT DAMAGE AND/OR IMPROPER OPERATION.

All 15 kV. Type DHP-VR Breakers utilize the DHP-VR SURE CLOSE MECHANISM to control MOC velocity and closely mimic the dynamics and velocities of older breakers. It is imperative that this mechanism be adjusted to match the number of MOC switches (from 0 to 3) mounted in the cell. If the adjustment is made on the DHP-VR breaker to be compatible with one housing with a given number of MOC switches, make sure the adjustment is checked and compatible if the breaker is moved to a different housing.

The breaker has been factory adjusted to operate one mechanism operated cell (MOC) switch in the cell. This means that for applications with either no MOC switch or one MOC switch, no field adjustments are required. It is only for the cases of 2 or 3 MOC switches that the

It is only for the cases of 2 or 3 MOC switches that the drive spring adjustment is required. The adjustment is done with the breaker out of the cell, open and all springs discharged. Refer to Figures 4-1 through 4-6 for reference assistance.

Finally, the SURE CLOSE mechanism provides an effective way to evaluate the condition of the MOC in the cell. If the SURE CLOSE drive spring is properly adjusted, but the MOC does not fully open or close, it is time to maintain the MOC in the cell. Maintenance usually means cleaning and lubricating the MOC mechanism. If the MOC has seen a large number of cycles, however, worn components may have to be replaced.

To adjust the SURE CLOSE drive spring for a specific number of MOC switches, proceed with the following steps:

Step 1: Remove the right hand phase barrier from the breaker (Figure 3-5).

Step 2: Locate the MOC drive spring (Figure 4-1). It is located in the left lower portion of the breaker as viewed from the top rear of the breaker with the phase barriers removed.

Step 3: From the factory, the drive spring comes set for 0 or 1 MOC switch. Refer to Figure 4-2 to see how that adjustment would look. Notice that there is a nut and a jam nut on the threaded rod to make the adjustment easy. Also notice that a step gauge is provided and bolted next to the spring to further simplify the adjustment (Figures 4-2 and 4-3).

Step 4: Anytime an adjustment is made, use a straight-edge to make sure that the flat surface end of the spring is properly aligned with the correct step on the gauge for the number of installed MOC switches. Figure 4-4 shows the alignment being checked for one installed MOC switch. Always refer back to the graphic in Figure 4-3 to ensure adjustment of the spring to the proper step on the gauge for the number of installed MOC switches.

Step 5: Refer to Figures 4-5 and 4-6 to see the drive spring adjusted for 2 installed MOC switches and 3 installed MOC switches respectively.

Step 6: Any time an adjustment is made, make sure that all nuts are secured in place and double check for proper adjust with a straightedge as described in Step 4.

Step 7: When the adjustment is completed, be sure to properly replace and secure the phase barrier removed in Step 1.

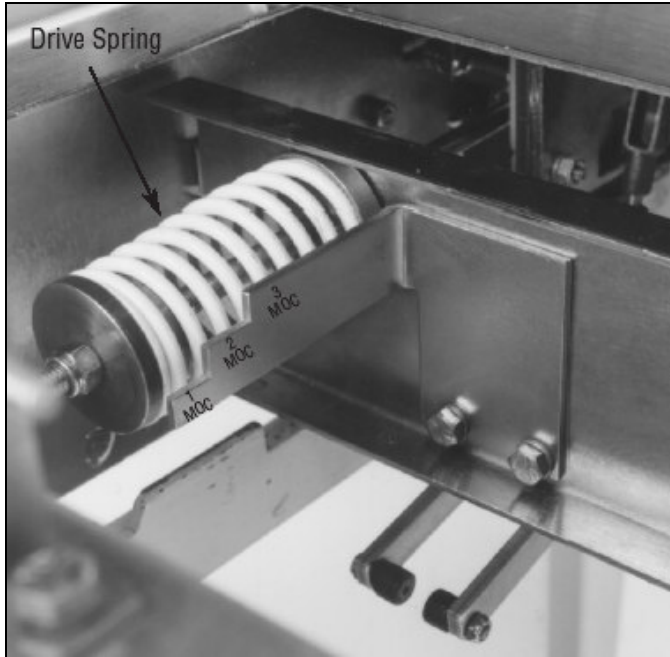

Figure 4-1 MOC driving spring.

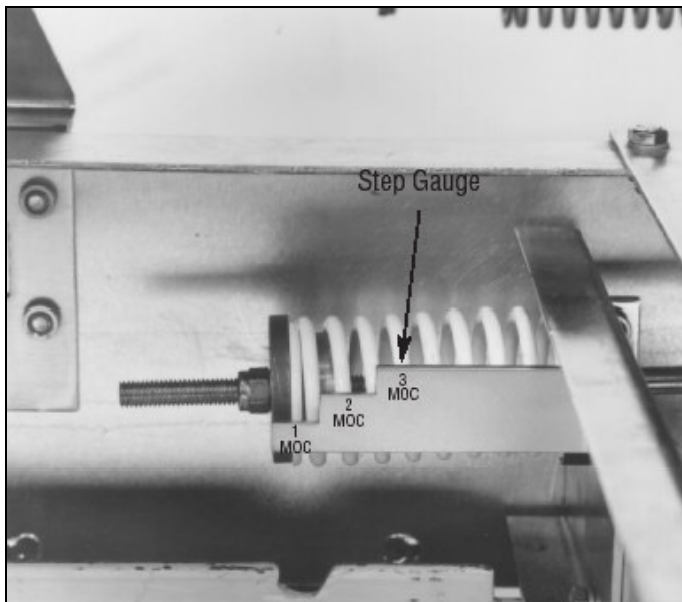

Figure 4-2 Drive Spring Adjusted for 0 or 1 MOC Switch

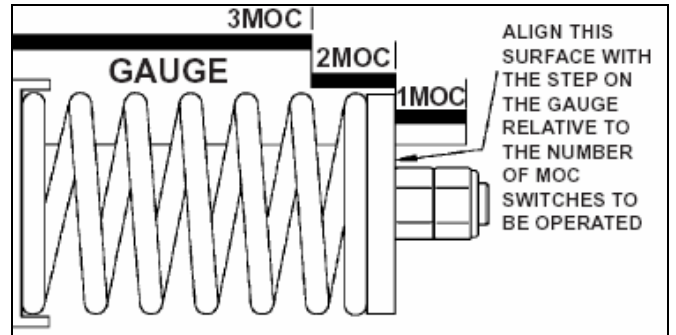

Figure 4-3 Drive Spring Adjustment Graphic

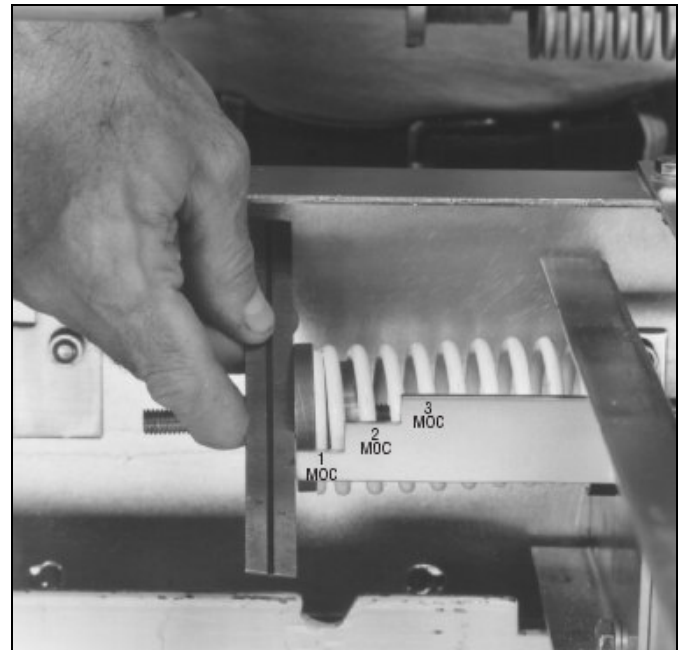

Figure 4-4 Checking Drive Spring for Proper Adjustment for One Installed MOC Switch

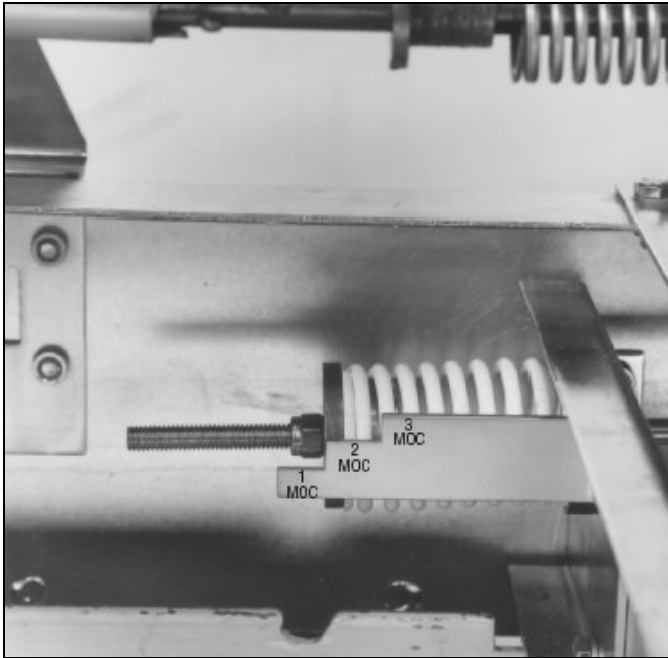

Figure 4-5 Drive Spring Shown Adjusted for 2 MOC Switches

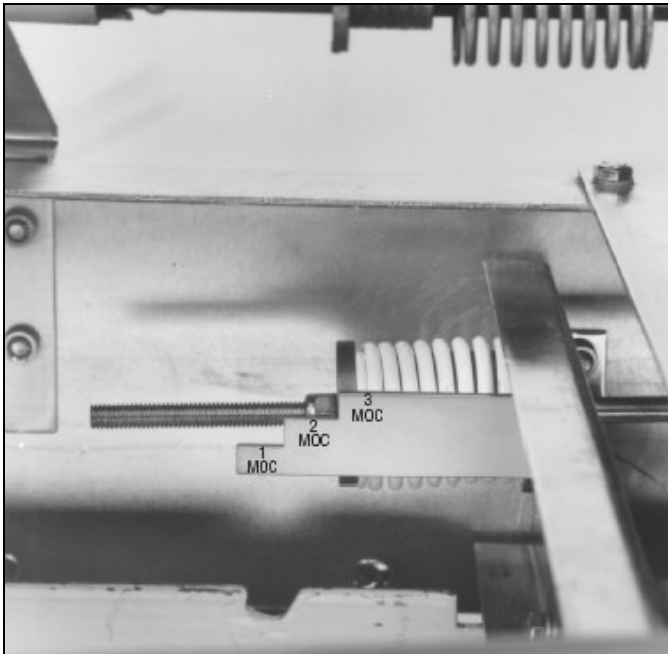

Figure 4-6a Drive Spring Shown Adjusted for 3 MOC Switches

4-3 MECHANISM OPERATED CELL (MOC) SWITCH PANTOGRAPH ADJUSTMENT



CAUTION

FOR ALL TYPE DHP HOUSINGS EQUIPPED WITH

MECHANISM OPERATED CELL (MOC) SWITCHES, THE STEPS OUTLINED IN THIS PARAGRAPH MUST BE PERFORMED BEFORE INSTALLING A REPLACEMENT DHP-VR CIRCUIT BREAKER. FAILURE TO COMPLETE THESE STEPS COULD RESULT IN EQUIPMENT DAMAGE AND/OR IMPROPER OPERATION.

Inspect the MOC pantograph in keeping with the following steps and refer to Figure 4-7 additional assistance.

Step 1: Check for excessive wear in the bearing surfaces of all pivoting members.

Step 2: Check that the pantograph assembly is securely bolted to the housing and that there is no missing hardware.

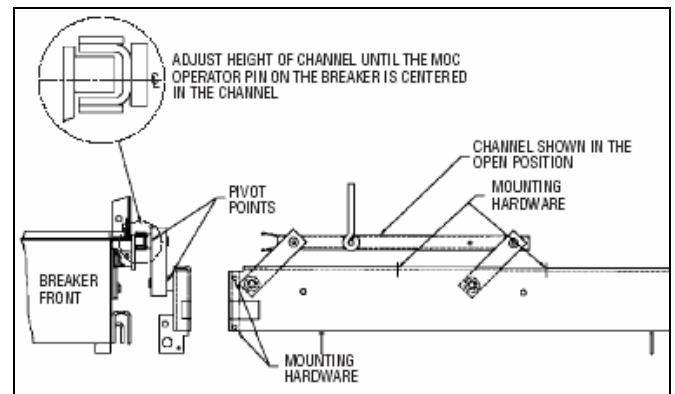

Figure 4-1 MOC Pantograph Adjustment.

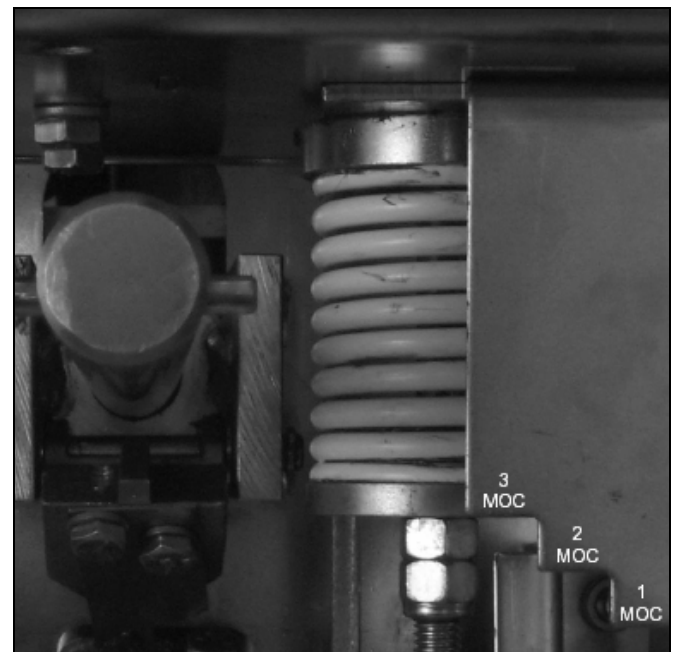

Figure 4-6b 5kV Drive Spring Adjusted for 3 MOC Switches

Step 3: Check that the top surface of the pantograph channel is adjusted so the MOC operator pin on the breaker is centered in the channel.

4-4 MANUAL OPERATION CHECK

Place the maintenance tool into the manual charge socket opening and charge the closing springs with about 36 up and down strokes of the handle. When charging is complete, the closing crank goes over center with an audible “click” and the springs Charged / Discharged Indicator shows “Charged”.

NOTICE

If the springs are to be charged on a closed breaker, no click is heard at the end of charging operation. Discontinue charging and remove the maintenance tool as soon as “Charged” flag is fully visible. Continued attempts to further charge may result in damage to the mechanism.

Remove the maintenance tool.
Close and trip the breaker several times.

4-5 VACUUM INTERRUPTER INTEGRITY

Using a dry lint-free cloth or a paper towel, clean all the insulating surfaces of the pole units. Conduct a vacuum interrupter integrity check as described in Section 6-4.

4-6 INSULATION

Check breaker primary and secondary insulation per Section 6-7.

4-7 CONTACT EROSION AND WIPE

Manually charge the closing springs and close the breaker. Check contact erosion and wipe as described in Section 6-5.

4-8 PRIMARY CIRCUIT RESISTANCE

Check the primary circuit resistance as described in Section 6-8. The resistance should not exceed the values specified. Record the values obtained for future reference.

4-9 NAMEPLATE

Compare the breaker nameplate information with switchgear drawings for compatibility. Breaker and compartment code plates do match power ratings, but do not match control voltages.

4-10 SNUBBER ADJUSTMENT



FOR ALL TYPE DHP HOUSINGS, THE ADJUSTMENT STEPS OUTLINED IN THIS PARAGRAPH MUST BE PERFORMED BEFORE INSTALLING A REPLACEMENT DHP-VR CIRCUIT BREAKER. FAILURE TO COMPLETE THESE STEPS COULD RESULT IN EQUIPMENT DAMAGE AND/OR IMPROPER OPERATION.

Before levering a breaker into any and all housings, the snubber bolts must be adjusted as outlined in steps 1 and 2. Refer to Figures 3-3, 3-5 and 4-8 for reference purposes. If a breaker is moved from one housing to another, the procedure must be repeated for the new housing.

Step 1: Measure the distance from the floor plate to the underside of the current transformer shelf on both sides of the housing in line with the location of the snubber bolts on each side of the breaker (Figure 4-8).

Step 2: Adjust the height of the top of the snubber bolt to be between 0.0 and 0.031 (0.0 and 1/32) inches below the measured height of the current trans-former shelf and tighten the locking nut.

4-11 ELECTRICAL OPERATIONS CHECK

After going through the above steps, the breaker is now ready to be operated electrically. It is preferred that this check be made with the breaker in the Test position in the breaker compartment.

Since the Type DHP-VR Circuit Breaker is for use in existing DHP Metal-Clad Switchgear, installation procedures are similar. If it is necessary to reference anything in the breaker compartment, refer to the original instruction books supplied with the assembly.

Refer to Figures 3-2 through 3-5, depending upon the voltage rating of the breaker, for any parts identification required during these installation procedures.

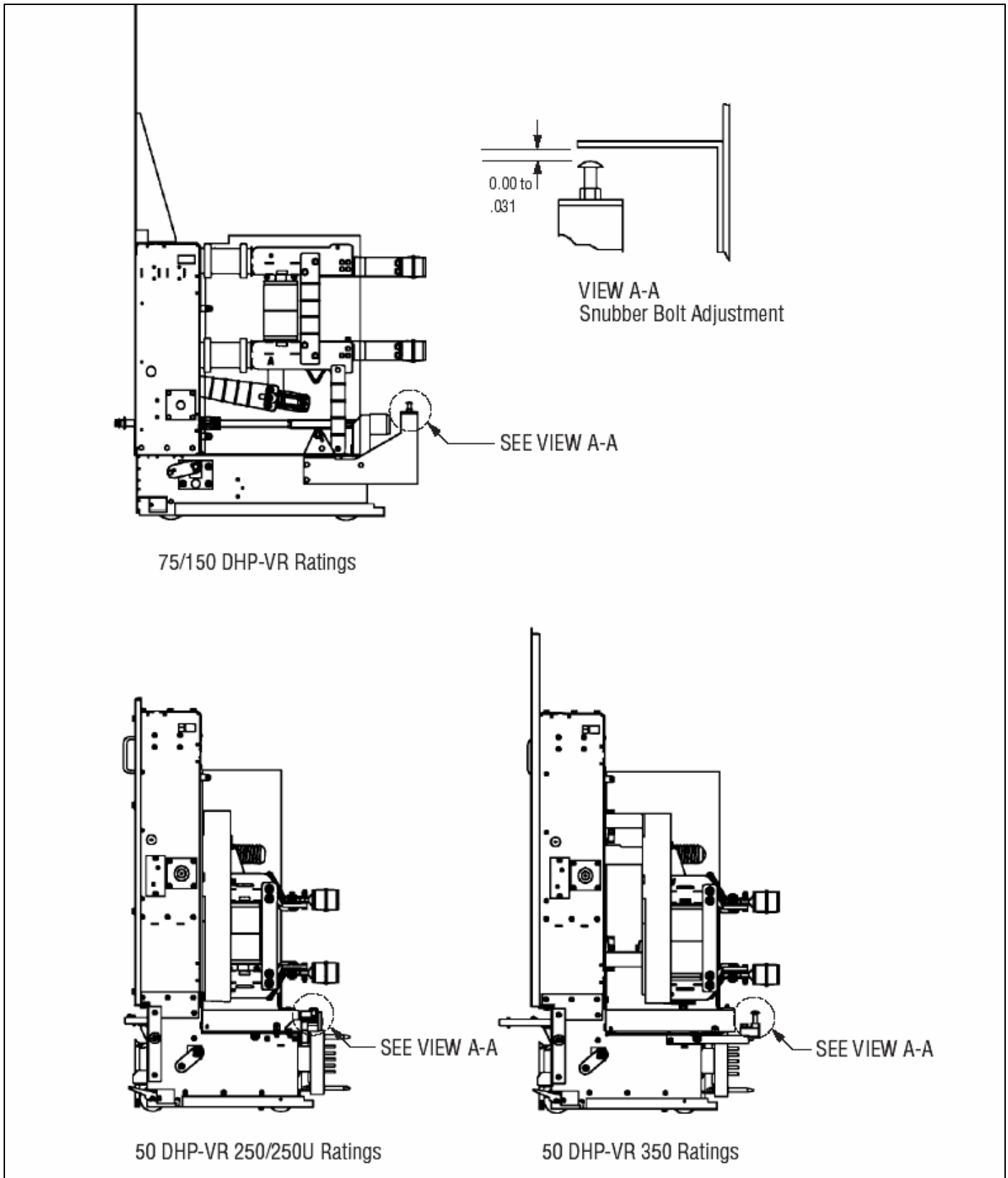

Figure 4-2 Snubber Adjustment

- a. The circuit breaker's faceplate and barriers must be positioned properly and securely bolted in position, as shown in Figures 3-2 through 3-5, before inserting the breaker into the cell.



CAUTION

EXAMINE THE INSIDE OF THE CELL BEFORE INSERTING THE BREAKER FOR EXCESSIVE DIRT OR ANYTHING THAT MIGHT INTERFERE WITH THE BREAKER TRAVEL.



WARNING

KEEP HANDS OFF THE TOP EDGE OF THE FRONT BARRIER WHEN PUSHING A BREAKER INTO A CELL. FAILURE TO DO SO COULD RESULT IN BODILY INJURY, IF FINGERS BECOME WEDGED BETWEEN THE BREAKER AND THE CELL. USE THE HANDLES PROVIDED ON THE FRONT OF THE BREAKER FACEPLATE, OR USE BOTH FULLY OPENED HANDS FLAT ON THE FRONT OF THE FACEPLATE.

- b. Position the breaker in front of the cell, and line up the guide channel on the rear right hand side of the breaker near the floor with the guide rail on the right hand side of the cell floor. Once the breaker is aligned with the cell floor guide, push the breaker into the cell until the rail latch at the front of the guide channel catches in a notch in the guide rail, and prevents further movement of the breaker toward the rear of the cell (Figures 4-9 and 4-10). The breaker is now in the Test position, and secondary contacts can be engaged.

NOTICE

As soon as the secondary contacts make up, the motor will charge the closing spring, if the control circuit is energized.

- c. To engage the secondary contacts on the 5kV design, lift the handle on the front left hand side of the breaker chassis to a horizontal position. Once the rod is pointing straight out from the breaker, push it manually to the rear until the secondaries are initially engaged. At this point, the small horizontal pin in the handle will have engaged two slots in the lever, which is pivoted immediately above the handle. To insure complete secondary engagement, push down firmly on the curved end of the lever as far as it will go,

using your foot or hand (Figure 4-11). When using a foot, care should be taken not to bend the lever by using excessive force.

- d. To engage the secondary contacts on the 7.5 or 15kV designs, unlatch the secondary operating rod, and move it to the left, until it points straight out from the breaker. Push the rod manually to the rear until the secondaries are initially engaged. Once initial engagement is achieved, hold the operating rod firmly in that position with one hand, while grasping the secondary engaging handle with the other hand. The secondary engaging handle is located to the right of the operating rod, just inside a rectangular hole. By pulling firmly on the engaging handle, complete secondary engagement will be insured (Figure 4-12).

- e. The breaker may now be electrically closed and tripped by using a control switch on the cell door, or it may be manually operated by means of the close and trip buttons, located on the faceplate of the breaker.



Figure 4-9 Positioning of 5 kV DHP-VR Breaker



Figure 4-10 Positioning of 7.5 or 15 kV DHP-VR Breaker



Figure 4-12 Final Engagement of 7.5 or 15 kV Secondary Contact



Figure 4-11 Final Engagement of 5 kV Secondary Contact

4-12 LEVER BREAKER INTO CELL

Trip the breaker open before attempting to lever it into the cell. A mechanical interlock will prevent levering the breaker into or out of the cell, if the breaker is closed.



CAUTION

EXCESSIVE FORCE, APPLIED TO THE LEVERING-IN MECHANISM WHILE THE BREAKER IS CLOSED, COULD SHEAR OFF THE PIN THAT THE LEVERING CRANK ENGAGES DURING OPERATION.

WHILE LEVERING THE BREAKER, NOTE ANY SUDDEN RESISTANCE TO LEVERING OR SIGNS OF BINDING. DETERMINE THE CAUSE OF INTERFERENCE AND CORRECT, AS APPROPRIATE, BEFORE PROCEEDING.

Press down on the rail latch on the front right side of the breaker with your foot, and push the breaker toward the rear of the cell as far as it will go. Be sure the breaker is pushed in until it stops. This will bring the leveringing nut on the breaker up to the screw in the cell.

Engage the leveringing crank on the leveringing shaft, push moderately toward rear of cell, and turn crank clockwise.

The breaker will move slowly toward the rear of the cell. After the breaker starts to move, it is not necessary to push (Figures 4-13 and 4-14). Continue cranking until the crank turns freely, and the breaker stops moving. When the breaker is fully engaged, the front face-plate will almost touch the cell frame angles. The breaker is now in the OPERATING or ENGAGED position, and may be operated electrically using the control switch on the cell door.

4-13 REMOVING BREAKER FROM CELL

NOTICE

The breaker may open and its closing spring may discharge as it is withdrawn from the cell. It depends on whether the breaker was left closed or open, or whether the spring was left charged or discharged.

To remove the breaker from the operating position, trip the breaker open, and engage the levering device shaft. Turn the crank counterclockwise until the crank rotates freely. Pull the breaker toward the front of the cell until the rail latch engages the slot in the rail. The breaker is now secured in the TEST position.

To remove the breaker from the cell, press down on the rail latch to free the breaker from the rail. Pull the breaker out of the cell.



Figure 4-13 Levering 5 kV Breaker to Connected Position



Figure 4-14 Levering 7.5 or 15 kV Breaker to Connected Position

SECTION 5: DESCRIPTION AND OPERATION

Cutler-Hammer Type DHP-VR breakers are horizontal drawout vacuum type removable interrupting elements for use in existing DHP Metal-Clad Switchgear. The breakers use vacuum interrupters to close and open the primary circuit. The mechanism is a front mounted spring stored energy type, which not only aids with personnel safety, but also provides ease of inspection and accessibility for servicing. The same basic mechanism is used for all ratings.

The DHP-VR vacuum circuit breaker is a direct roll in replacement for DHP air magnetic and DVP vacuum circuit breakers. It is wheel mounted for ease of handling and installation, and rolls in and out of the existing cell on the floor. Modifications to the existing DHP or DVP structures are not necessary in order to use DHP-VR breakers.

DHP-VR vacuum circuit breakers correctly interface with compartment cell switches (MOC and TOC switches). Circuit breaker coding plates are maintained to prevent an underrated circuit breaker from being installed in the switchgear.

Safety interlocks, inherent in the original switchgear design and required by ANSI Standards, are also maintained.

The primary insulation used on 5kV. DHP-VR vacuum circuit breakers is glass polyester, while the primary insulation used on 7.5 and 15 kV. DHP-VR vacuum circuit breakers is cycloaliphatic epoxy. Type SIS AWG# 14 wire, with cross-linked polyolefin insulation is used on all DHP-VR control circuits. Secondary control terminations on all DHP-VR breakers are ring type terminations, consistent with existing DHP circuit breakers.

5-1 INTERRUPTER ASSEMBLY

Vacuum interrupters are mounted vertically and are supported from the fixed stem clamped to the bottom conductor on the 5kV. design (Figure 5-1), and the top conductor on the 7.5 or 15kV. design (Figure 5-2). A close inspection of the two figures will reveal that the 5kV. design is actually inverted, relative to the 7.5 or 15kV. design. In both instances, however, the DHP-VR includes the Cutler-Hammer patented V-flex current transfer system. The current transfer system itself consists of a series of tin-plated, high-conductivity copper leaf conductors that are swaged onto the movable interrupter stem. This provides a multipoint contact resulting in low electrical and thermal resistance. Since the current transfer from the movable stem to the circuit breaker main conductor is a nonsliding design, no maintenance is required.



Figure 5-1 DHP-VR 5k V Interrupter Assembly

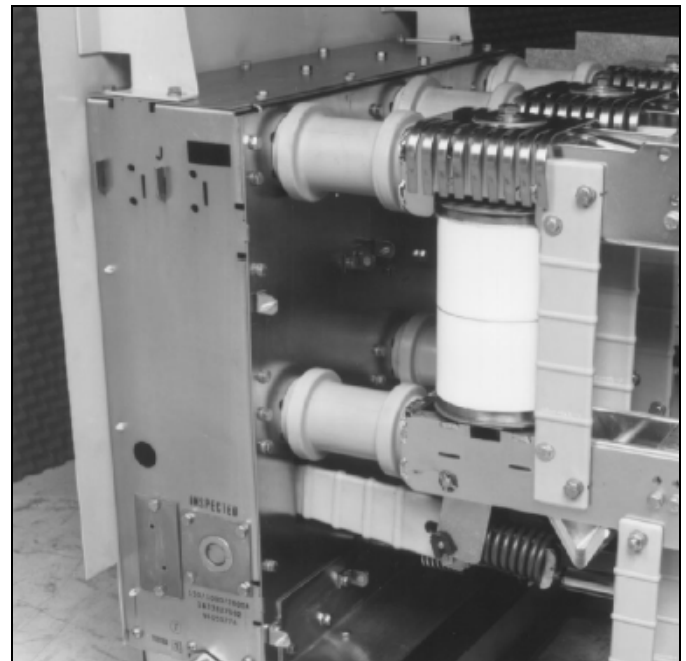

Figure 5-2 DHP-VR 7.5 or 15 kV Interrupter Assembly

The vacuum interrupter system on all DHP-VR breakers utilizes a visible “T” cutout contact loading spring indicator. This “T” indicator is used to indicate that the loading springs are maintaining the proper contact pressure to keep the contacts closed (Figures 5-1 and 5-2).

5-1.1 VACUUM INTERRUPTER

Type DHP-VR breakers utilize vacuum interrupters for interruption and switching functions. Vacuum interruption offers the advantages of enclosed interrupters, reduced size and weight, short interrupting time, long life, reduced maintenance, and environmental compatibility.

Arc interruption is simple and fast. In the closed position, current flows through the interrupter. When the contacts are opened, the arc is drawn between the contact surfaces. It is rapidly moved around the slotted contact surfaces by a self-induced magnetic force, which prevents gross contact erosion, as well as the formation of hot spots on the contact surfaces. The arc burns in an ionized metal vapor, which continually leaves the contact area and condenses on the surrounding metal shield.

At current zero, the arc is extinguished and vapor production ceases. Very rapid dispersion, cooling, recombination, and deionization of the metal vapor plasma, together with the fast condensation of metal vapor products, cause the vacuum to be quickly restored. Hence, the opened contacts withstand the transient recovery voltage.

5-1.2 CONTACT EROSION INDICATOR

The purpose of the contact erosion indicator is to monitor the erosion of the vacuum interrupter contacts, which is very minimal over time with Cutler-Hammer vacuum interrupters utilizing copper-chrome contact material. If contact erosion reaches 1/8 inch, the interrupter must be replaced. A contact erosion indicator mark is located on the moving stem of the interrupter (Figures 6-2 and 6-3).

In order to determine if the contacts have eroded to the extent that the interrupter must be replaced, close the breaker and observe the erosion mark placed on each moving stem from the rear of the breaker. If the mark on the interrupter stem is visible, the interrupter is satisfactory. If the mark is no longer visible, the interrupter assembly must be replaced.

The erosion indicator is easily viewed from the rear on the 7.5 or 15kV. designs. Because of the nature of the 5kV. DHP-VR inverted design, the erosion indicator is not easily viewed, although it is possible with the use of a light and a dental type mirror.

5-1.3 “T” CUTOUT LOADING SPRING INDICATOR

Since the “T” cutout loading spring indicator is part of all DHP-VR breaker designs, an additional method is provided that will indicate conditions within the interrupter, as well as the overall system condition. The visible “T” indicator is used to indicate whether the loading springs are maintaining the proper contact pressure to keep the contacts closed. Severe contact erosion would lead to an unacceptable indication from the “T” indicator (Figures 6-4 and 6-5).

5-1.4 CONTACT WIPE AND STROKE

Contact wipe is the indication of (1) the force holding the vacuum interrupter contacts closed and (2) the energy available to hammer the contacts open with sufficient speed for interruption.

Stroke is the gap between fixed and moving contacts of a vacuum interrupter with the breaker open.

The circuit breaker mechanism provides a fixed amount of motion to the operating rods. The first portion of the motion is used to close the contacts (i.e. stroke) and the remainder is used to further compress the preloaded wipe spring. This additional compression is called wipe. Wipe and stroke are thus related to each other. As the stroke increases due to the erosion of contacts, the wipe decreases. A great deal of effort has been spent in the design of all Cutler-Hammer vacuum breakers, in order to eliminate the need for field adjustments of wipe or stroke.



CAUTION

THERE IS NO PROVISION FOR IN-SERVICE ADJUSTMENTS OF CONTACT WIPE AND STROKE. ALL SUCH ADJUSTMENTS ARE FACTORY SET AND SHOULD NOT BE ATTEMPTED IN THE FIELD.

5-1.5 PHASE BARRIERS



WARNING

DO NOT PLACE THE BREAKER IN ITS COMPARTMENT WITHOUT THE PHASE BARRIERS IN PLACE. THE ABSENCE OF BARRIERS CAN CAUSE A CATASTROPHIC FAILURE DURING AN INTERRUPTION OR OPERATION, CAUSING DEATH, SEVERE PERSONAL INJURY OR PROPERTY DAMAGE.

Phase barriers on all DHP-VR breakers are made of glass polyester. They are all secured in place by bolts, and are part of the breaker assembly. The 5kV. DHPVR breaker utilizes 4 barriers, while the 7.5 or 15 kV. designs utilize 5 barriers (Figures 3-3 and 3-5).

5-2 STORED ENERGY MECHANISM



WARNING

KEEP HANDS AND FINGERS AWAY FROM THE BREAKER'S INTERNAL PARTS WHILE THE BREAKER CONTACTS ARE CLOSED OR THE CLOSING SPRINGS ARE CHARGED. THE BREAKER CONTACTS MAY OPEN OR THE CLOSING SPRINGS DISCHARGE CAUSING A CRUSHING INJURY. DISCHARGE THE SPRINGS AND OPEN THE BREAKER BEFORE PERFORMING ANY MAINTENANCE, INSPECTION OR REPAIR ON THE BREAKER.

The spring stored energy operating mechanism is arranged vertically in front of all DHP-VR breakers. It includes all the elements for storing the energy, closing and tripping of the breaker, as well as manual and electrical controls. The manual controls are all front accessible. Motion to close and open the interrupter contacts is provided through operating rods connecting the mechanism pole shaft to the bell cranks of the interrupter assemblies (Figures 5-3 and 5-4).

5-2.1 OPERATION OF STORED ENERGY MECHANISM

The mechanism stores the closing energy by charging the closing springs. The mechanism may rest in any one of the four positions shown in Figure 5-5 and as follows:

- Breaker open, closing springs discharged
- Breaker open, closing springs charged
- Breaker closed, closing springs discharged
- Breaker closed, closing springs charged

5-2.2 CHARGING

Figure 5-6 is a schematic view of the spring charging parts of the stored energy mechanism.

The major component of the mechanism is a cam shaft assembly which consists of a drive shaft to which are attached two closing spring cranks (one on each end), the closing cam, drive plates, and a free-wheeling ratchet wheel. The ratchet wheel is actuated by an oscillating mechanism driven by the motor eccentric. As the ratchet wheel rotates, it pushes the drive plates which, in turn, rotate the closing spring cranks and the closing cam with it.

The closing spring cranks have spring ends connected to them, which are in turn coupled to the closing springs. As the cranks rotate, the closing springs are charged. When the closing springs are completely charged, the spring cranks go over dead center, and the closing stop roller comes against the spring release latch. The closing springs are now held in the fully charged position.

Closing springs may also be charged manually. Insert the maintenance tool in the manual charging socket (Figures 3-2 and 3-4). Move it up and down approximately 36 times until a clicking sound is heard, and the closing springs charging indicator indicates "Charged". Any further motion of the maintenance tool will result in free wheeling of the ratchet wheel.

5-2.3 CLOSING OPERATION

Figure 5-5 shows the positions of the closing cam and tripping linkage. Note that in Figure 5-5a, in which the breaker is open and the closing springs are discharged, the trip "D" shaft and the trip latch are in the unlatched position.

Once charged, as in Figure 5-5b the closing springs can be released to close the breaker by moving the spring release latch out of the way. This is done electrically or manually by depressing the spring release lever, which turns the spring release latch out of the way of the closing stop roller. The force of the closing spring rotates the cam shaft through the spring cranks. The closing cam, being attached to the cam shaft, in turn rotates the pole shaft through the main link to close the breaker.

In Figure 5-5c the linkage is shown with the breaker in the closed position before the closing springs have been recharged. Interference of the trip "D" shaft with the trip latch prevents linkage from collapsing, and the breaker is held closed.

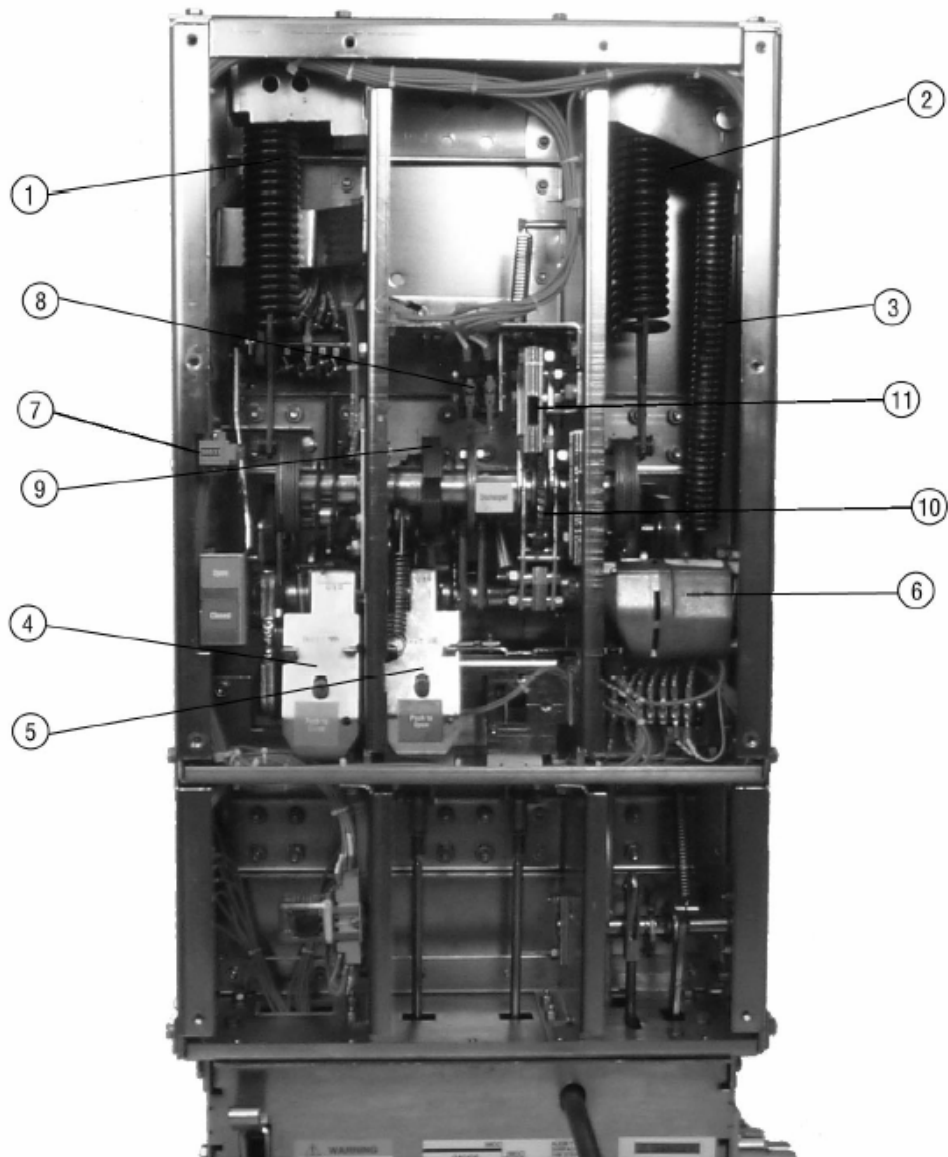

- | | |
|---------------------------|------------------------|
| ① LH Closing Spring | ⑦ Operations Counter |
| ② RH Closing Spring | ⑧ Motor Cutoff Switch |
| ③ Reset Opening Spring | ⑨ Closing Cam |
| ④ Spring Release Assembly | ⑩ Ratchet Wheel |
| ⑤ Shunt Trip Assembly | ⑪ Manual Charge Socket |
| ⑥ Charging Motor | |

Figure 5-3 DHP-VR 5 kV Design - Front Faceplate Removed

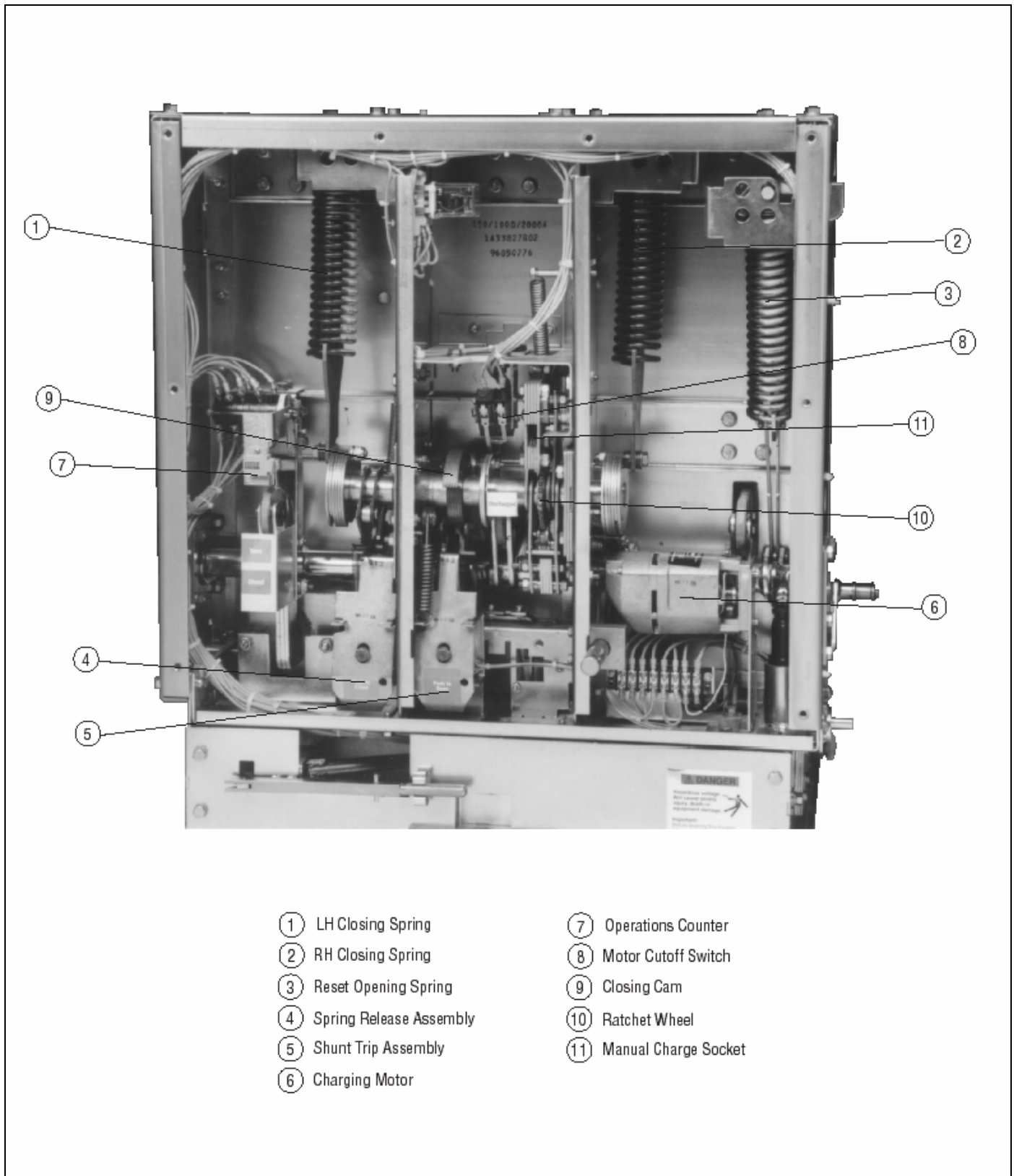

- | | |
|---------------------------|------------------------|
| ① LH Closing Spring | ⑦ Operations Counter |
| ② RH Closing Spring | ⑧ Motor Cutoff Switch |
| ③ Reset Opening Spring | ⑨ Closing Cam |
| ④ Spring Release Assembly | ⑩ Ratchet Wheel |
| ⑤ Shunt Trip Assembly | ⑪ Manual Charge Socket |
| ⑥ Charging Motor | |

Figure 5-4 DHP-VR 7.5 or 15 kV Design - Front Faceplate Removed

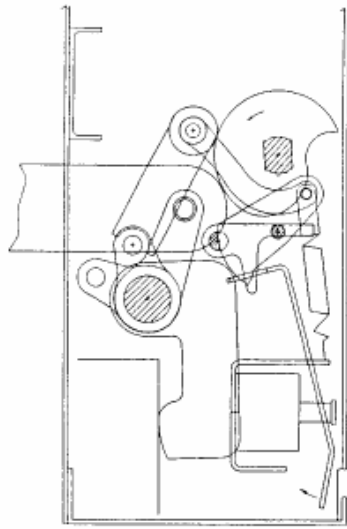

Figure 5-5a Breaker Open and Closing Spring Not Charged

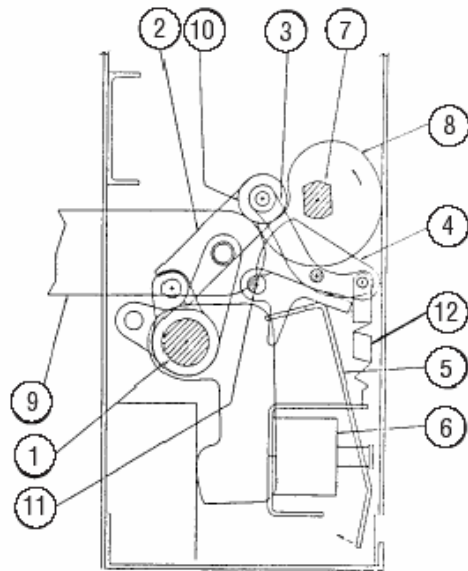

Figure 5-5b Breaker Open and Closing Spring Charged

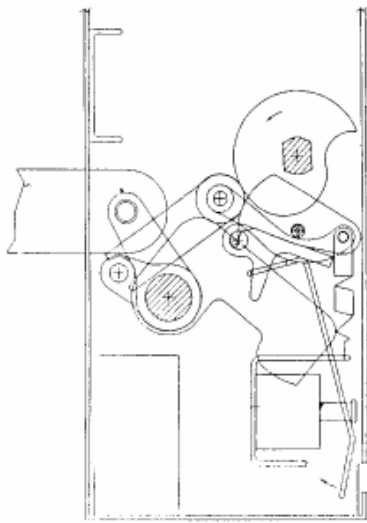

Figure 5-5c Breaker Closed and Closing Spring Not Charged

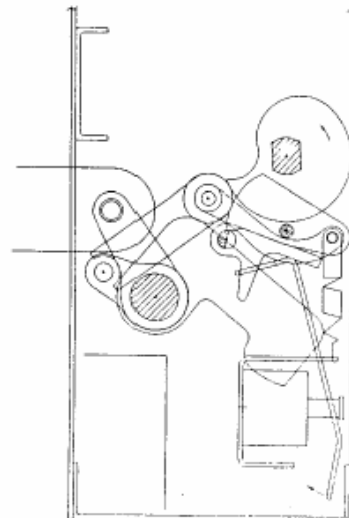

Figure 5-5d Breaker Closed and Closing Spring Charged

① Pole Shaft

② Main Link

③ Banana Link

④ Trip Latch

⑤ Shunt Trip Lever

⑥ Shunt Trip Coil

⑦ Cam Shaft

⑧ Closing Cam

⑨ Operating Rod

⑩ Main Link Roller

⑪ Trip Bar 'D' Shaft

⑫ Trip Latch Reset Spring

Figure 5-5 Closing Cam and Trip Linkage

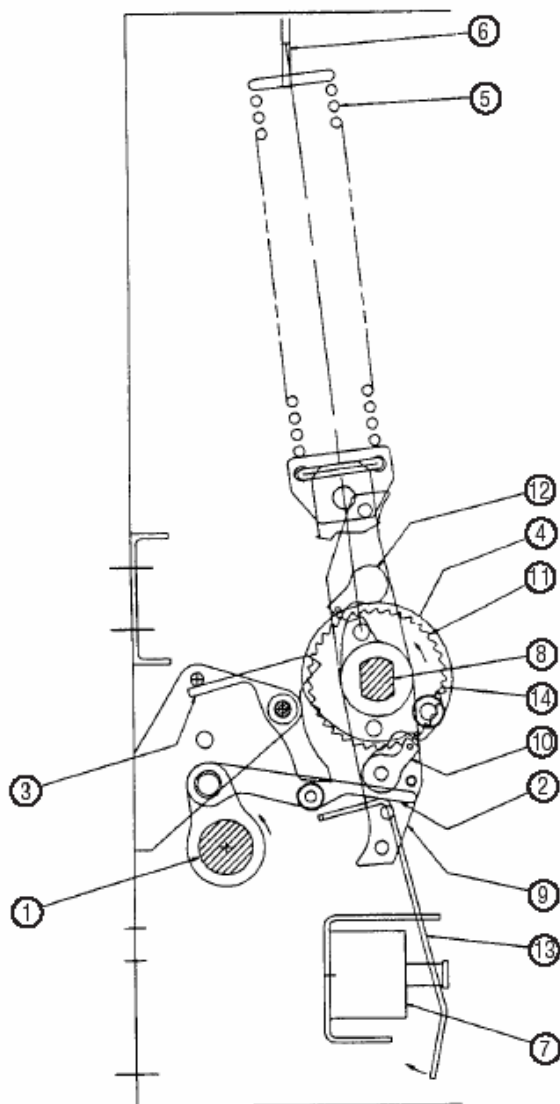

Breaker Open, Springs Discharged

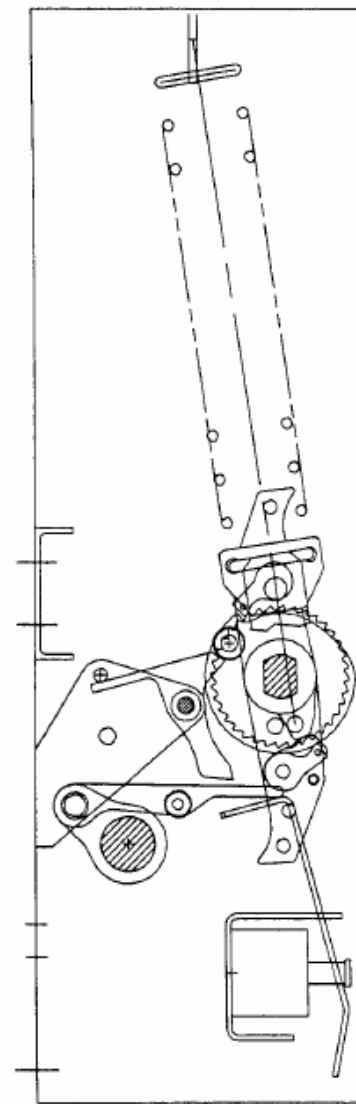

Breaker Closed, Springs Charged

- ① Pole Shaft
- ② Anti-Close Interlock
- ③ Spring Release (Close) Latch
- ④ Spring Crank
- ⑤ Closing Spring
- ⑥ Closing Spring Fixed End
- ⑦ Spring Release (Close) Coil

- ⑧ Cam Shaft
- ⑨ Motor Ratchet Lever
- ⑩ Drive Pawl
- ⑪ Ratchet Wheel
- ⑫ Holding Pawl
- ⑬ Spring Release (Close) Clapper
- ⑭ Spring Release Latch (Close Roller)

Figure 5-6 Charging Schematic

Figure 5-5d shows the breaker in the closed position after the closing springs have been recharged. Note that the spring charging rotates the closing cam by one half turn. Since the cam surface in contact with the main link roller is cylindrical in this region, the spring charging operation does not affect the mechanism linkage.

Since the primary contacts are completely enclosed in the vacuum interrupter and not adjustable in any way, a "Slow Close" capability is not provided with DHP-VR breakers.

5-2.4 TRIPPING OPERATION

When the trip "D" shaft is turned either by the trip button or trip coil, all links return to the original "open" condition shown in Figure 5-5a.

5-2.5 TRIP FREE OPERATION

When the manual trip button is held depressed, any attempt to close the breaker results in the closing springs discharging, without any movement of the pole shaft or vacuum interrupter stem.

5-3 CONTROL SCHEME

There are two basic control schemes for type DHP-VR breakers, one for DC control and one for AC control (Figure 5-7). There may be different control voltages or more than one tripping element, but the principal mode of operation is as follows:

As soon as the secondary disconnects engage, the spring charging motor automatically starts charging the closing springs, provided control power is available. When the springs are charged, the motor cut off LS1/bb switch turns the motor off. The breaker may be closed by making the control switch close (CS/C) contact. Automatically upon closing of the breaker, the motor starts charging the closing springs. The breaker may be tripped any time by making the control switch (CS/T) contacts.

Note the position switch (PS1) contact in the spring release circuit in the scheme. This contact remains made while the breaker is being levered between the TEST and Connected positions. Consequently, it prevents the breaker from closing automatically, even though the control switch close contact may have been made while the breaker is levered to the Connected position.

When the CS/C contact is made, the SR closes the breaker. If the CS/C contact is maintained after the breaker closes, the Y relay is picked-up. The Y/a contact seals in Y until CS/C is opened. The Y/b contact opens the SR circuit, so that even though the breaker would subsequently open, it could not be reclosed before CS/C was released and remade. This is the anti-pump function.

5-3.1 TIMING

The opening and closing times for the circuit breakers vary depending upon the control voltage, power rating, environment and test equipment. Differences in timing are expected between initial factory measurements and field inspections. Circuit breaker timing can be measured by service personnel using available equipment before installation and in conjunction with regular maintenance periods to assist in tracking the general health of the breaker. Typical ranges as observed using nominal control voltages are as follows:

Table 5.1

Circuit Breaker Type	Time in Milliseconds
Closing Time (From Initiation of Close Make)	37.0-62.2
Opening Time (Initiation of Trip Signal to contact break)	30-45
Reclosing Time (Initiation of Trip Single to contact make)	140-165

5-3.2 SECONDARY DISCONNECTS

The breaker control wiring is arranged for drawout disconnecting by means of a 15 point male plug arranged to connect to a female receptacle mounted in the rear of the existing DHP cell. The secondary contact plug is mounted on a movable bracket on the left side of the breaker truck (Figures 5-8 and 5-9). This permits it to be extended to the rear while the breaker is in the test position to make with the stationary receptacle in the cell so that the control circuits are completed. Control wiring terminates first at terminal blocks mounted at the rear of the breaker truck, and continues from the terminal blocks to the male contact plug.

Normally the secondary contacts are held stationary relative to the breaker chassis. This is accomplished by a hinged joint in the hand operating rod which acts on the edge of the lower front truck panel to hold the assembly in position.

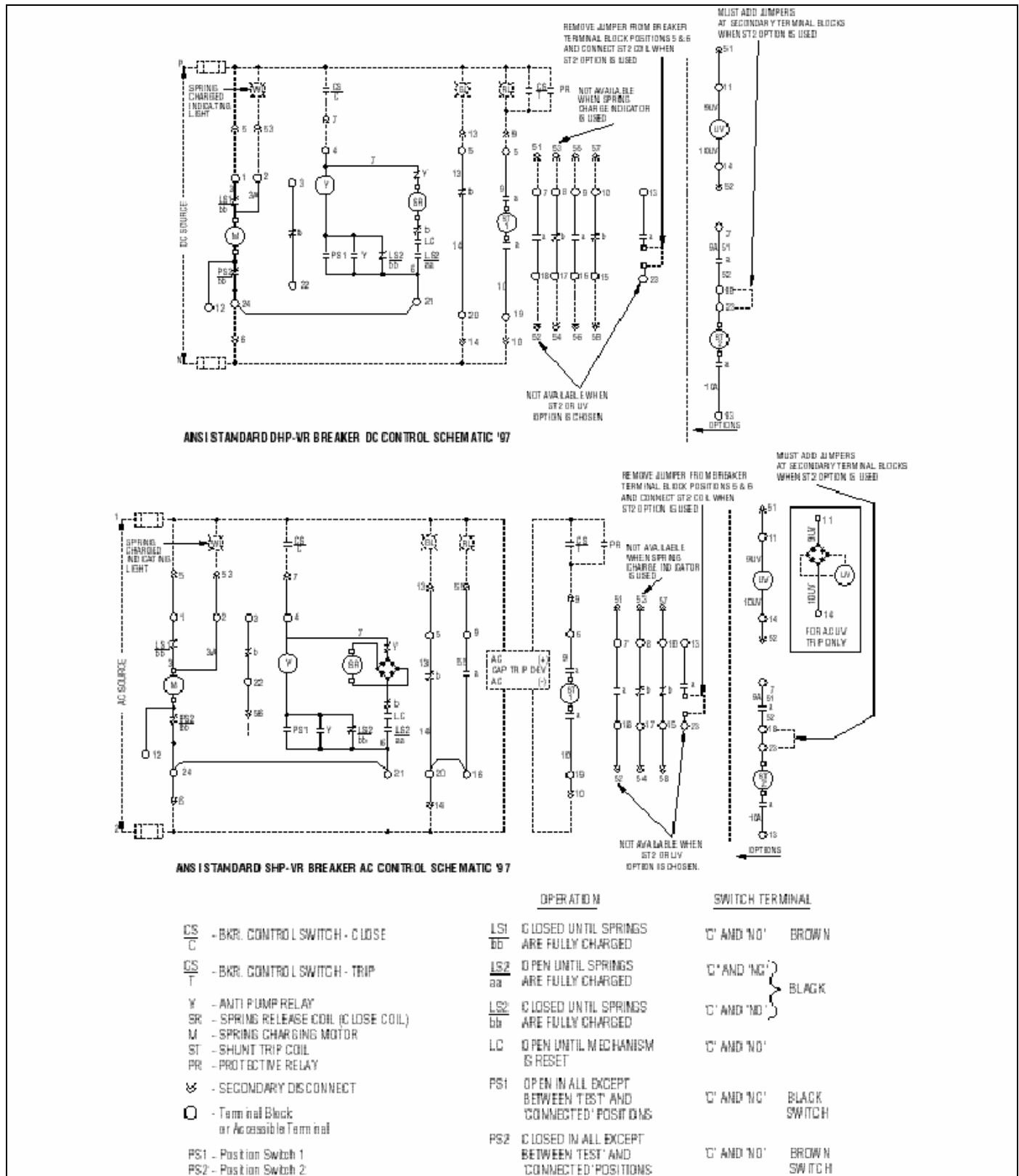

Figure 5-7 Typical DHP-VR "DC" and "AC" Control Schemes

To engage the secondary contacts on the 5kV. design while the breaker is in the test position, lift the handle on the front left hand side of the breaker chassis to a horizontal position. Once the rod is pointing straight out from the breaker, push it manually to the rear until the secondaries are initially engaged. At this point, the small horizontal pin in the handle will have engaged two slots in the lever, which is pivoted immediately above the handle. To insure complete secondary engagement, push down firmly on the curved end of the lever as far as it will go, using a foot or hand (Figure 4-11). When using a foot, care should be taken not to bend the lever by using excessive force.

To engage the secondary contacts on the 7.5 or 15kV. design while the breaker is in the test position, unlatch the secondary operating rod, and move it to the left until it points straight out from the breaker. Push the rod manually to the rear until the secondaries are initially engaged. Once initial engagement is achieved, hold the operating rod firmly in that position with one hand, while grasping the secondary engaging handle with the other hand. The secondary engaging handle is located to the right of the operating rod, just inside a rectangular hole. By pulling firmly on the engaging handle, complete secondary engagement will be insured (Figure 4-12).

5-4 INTERLOCKS



WARNING

NEVER DISABLE OR DEFEAT ANY INTERLOCKS. HAZARDOUS VOLTAGES WILL CAUSE DEATH, SEVERE PERSONAL INJURY OR PROPERTY DAMAGE.

All DHP-VR breakers are equipped with interlocks that are compatible with the existing DHP assembly structure. These interlocks will insure proper and safe breaker operation.

5-4.1 BREAKER-CELL CODING PLATES

This is a combination of a notched plate in the cell and interference bars on the breaker, so that only appropriately rated breakers can be put into the cell (Figures 5-10 and 5-11).

5-4.2 LEVERING-IN INTERLOCK

The levering-in interlock is designed to prevent moving the breaker into or out of the Operating position, if the

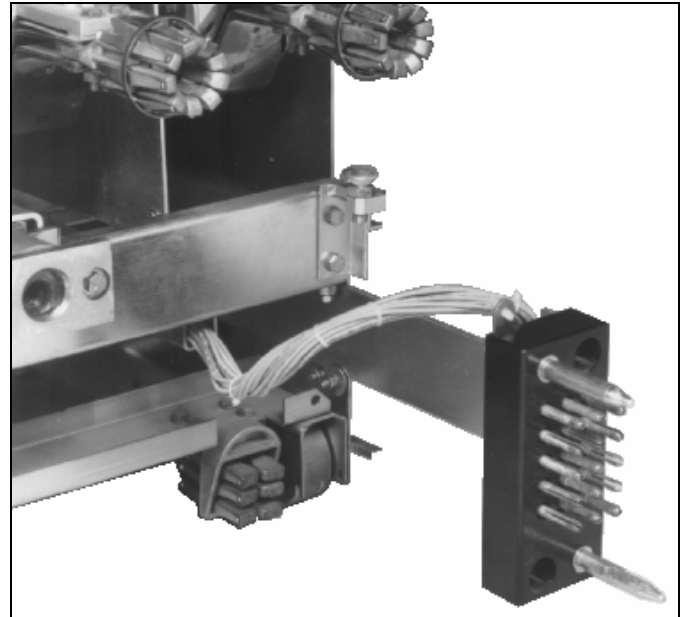

Figure 5-8 Male Secondary Contact Block (In Extended Position) On 5 kV DHP-VR Breaker

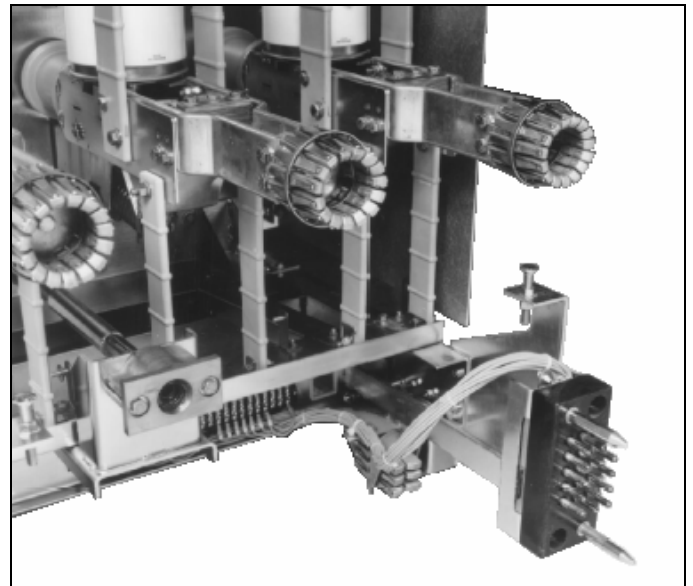

Figure 5-9 Male Secondary Contact Block (In Extended Position) On 15 kV DHP-VR Breaker

breaker contacts are closed. DHP-VR interlocks are completely compatible with the existing levering screw located in the existing DHP or DVP assembly structure.

DHP-VR 5kV. breakers utilize a levering-in interlock design that is very similar to the design used on DHP breakers. A key, which is spring operated by the closing and opening action of the breaker, prevents levering of the breaker, unless the breaker is open. Opening the breaker removes the key from the levering-in shaft key-way, and the breaker can be levered.

DHP-VR 7.5 and 15kV. breakers utilize a device that also prevents levering a breaker with the contacts closed, but is different in design from the 5kV. breaker. It consists of a plate supported by a pin between the two pole shaft levers. As the breaker closes, the plate falls into the levering-in shaft keyway, by virtue of gravity. Opening the breaker lifts the plate out of the keyway, and the breaker can be levered.

5-4.3 ANTI-CLOSE INTERLOCK

This interlock prevents release of the closing springs electrically or manually, if the breaker is already closed (Figure 5-6). On a closed breaker, the interlock lever moves toward the rear. In this position, the movement of the spring release clapper does not lift the lever, and thus the spring release latch cannot be moved.

5-4.4 FLOOR TRIPPING AND CLOSING SPRING RELEASE INTERLOCKS

The floor tripping and closing spring release interlocks operate to trip the breaker and discharge the closing spring when the breaker is inserted into the cell to the test position, or removed from the cell. Cam plates on the cell floor lift trip levers on the underside of the breaker to trip the breaker and/or discharge the closing springs (Figures 5-12 and 5-13).

The floor tripping interlock also operates to hold the breaker trip-free while it is traveling between the Test and Connected positions. This is to prevent accidental closing of the breaker in an intermediate position.

5-4.5 RAIL LATCH

The main function of the rail latch is to prevent damage to the levering-in screw and nut (Figures 5-14 and 5-15). It also functions to latch the breaker in the Test position, as previously described in Section 4-8b.

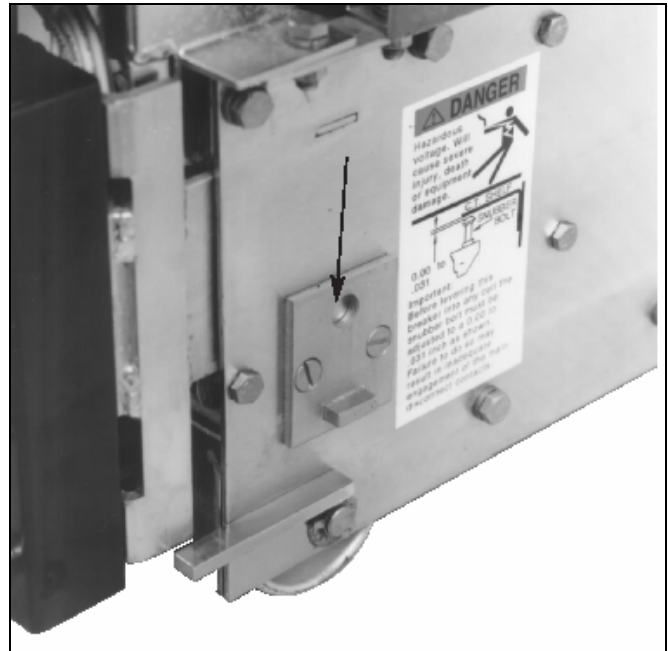

Figure 5-10 Code Plate Installed On 5 kV DHP-VR Breaker

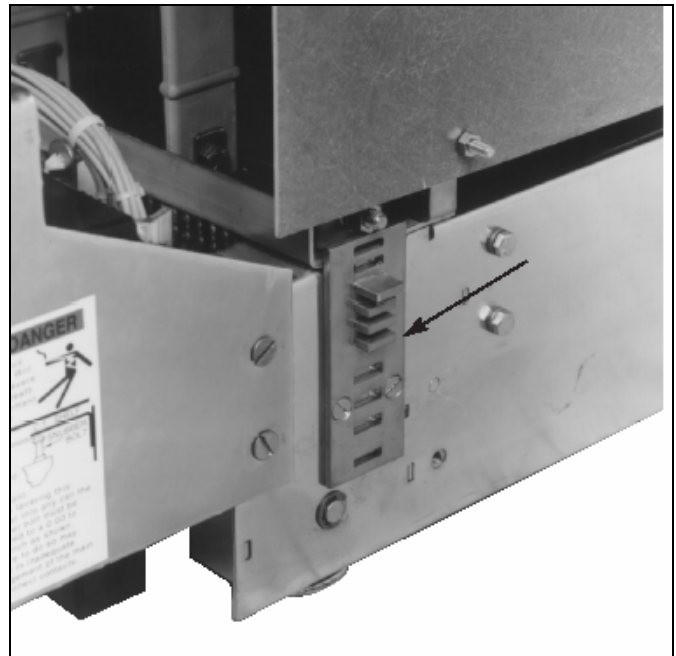

Figure 5-11 Code Plate Installed On 15 kV DHP-VR Breaker

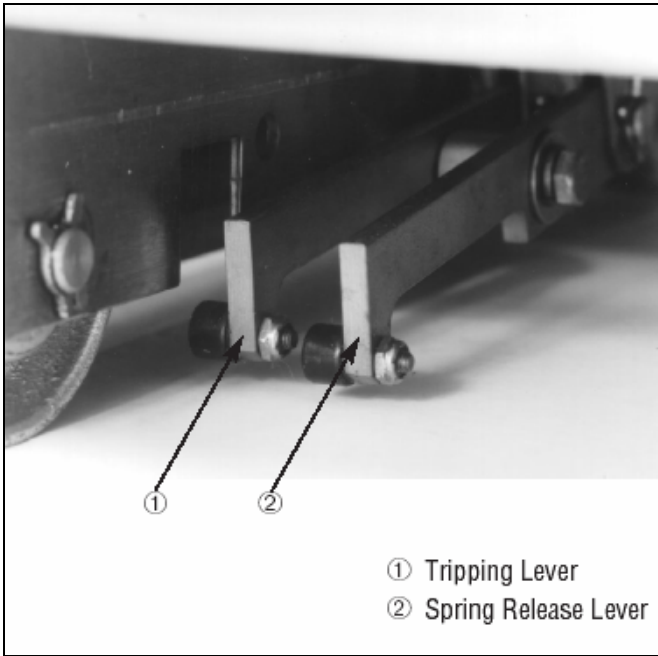

Figure 5-12 DHP-VR Breaker (5 kV) Floor Tripping Levers (Underneath Front View)

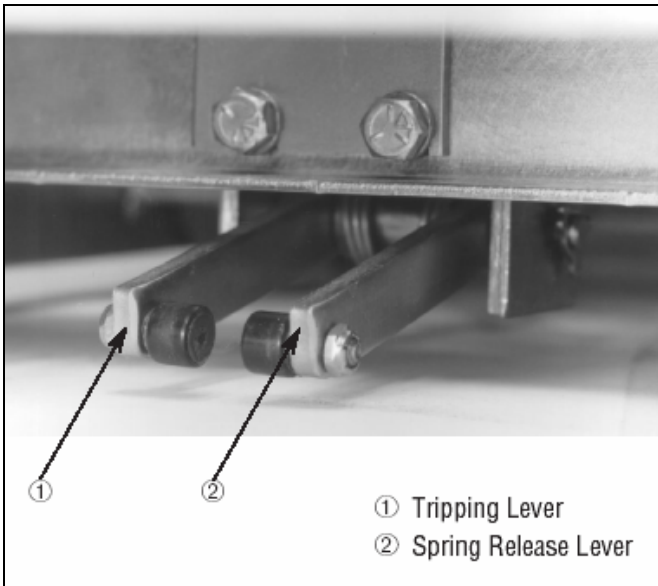

Figure 5-13 DHP-VR Breaker (7.5 or 15 kV) Floor Tripping Lever (Underneath Rear View)



Figure 5-14 DHP-VR Breaker (5 kV) Rail Latch

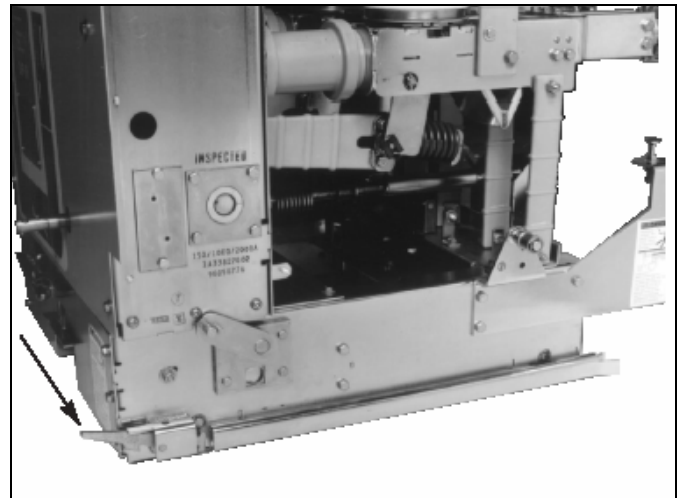

Figure 5-15 DHP-VR Breaker (7.5 or 15 kV) Rail Latch

5-5 MISCELLANEOUS ITEMS

5-5.1 GROUND CONTACT

The ground contact is an assembly of spring loaded fingers for all DHP-VR breaker designs providing a means for disconnecting the grounding of the breaker chassis, after it has been inserted into a switchgear cell (Figure 5-16). The ground contact is located on the underside of the chassis next to the secondary contact block. An extension of the switchgear ground bus is secured to the cell floor in such a position to engage the ground contact automatically, when the breaker is pushed into the Test position. It remains engaged in all positions from Test to and including Connected.

5-5.2 MOC AND TOC SWITCH OPERATIONS

A mechanism attached to the right side of the DHP-VR breaker engages a channel member of the Mechanism Operated Cell Switch (MOC) located in the switchgear cell (Figures 5-14 and 5-15). This mechanism permits the contacts of the MOC Switch to be correlated with the breaker's contact position.

NOTICE

All 15 kV. Type DHP-VR Breakers utilize the DHP-VR SURE CLOSE MECHANISM to control MOC velocity and closely mimic the dynamics and velocities of older breakers. It is imperative that this mechanism be adjusted to match the number of MOC switches (from 0 to 3) mounted in the cell. Always make sure the mechanism is properly adjusted in keeping with paragraph 4-2 of this manual before any attempt is made to insert the breaker into the cell.

In addition, the MOC pantograph must be checked in keeping with the instructions outlines in paragraph 4-3 before any attempt is made to insert the breaker into the cell.

The cell mounted Truck Operated Cell Switch (TOC) is operated by movement of the breaker truck into or out of the Connected position.

5-5.3 OPERATIONS COUNTER

All DHP-VR breakers are equipped with a mechanical operations counter (Figures 3-2 and 3-4). As the breaker opens, the linkage connected to the pole shaft lever advances the counter reading by one.

5-6 LEVERING DEVICE

The purpose of the levering device is to move the breaker between the Test and Connected positions. On the 7.5 or 15kV. DHP-VR, the levering-in mechanism is located in the mechanism, while it is located in the breaker truck on the 5kV. DHP-VR. The levering nut is fastened securely to the guide tube and is loosely retained in a housing fastened to the extreme rear of the breaker chassis (Figures 5-17 and 5-18).

The operation consists of engaging the rotatable levering nut on the circuit breaker with the levering screw mounted on the rear wall of the cell. By traversing the levering nut along the levering screw, the breaker is moved between positions within the switchgear housing.

The guide tube is slotted lengthwise for a distance about equal to the travel distance of the breaker. The levering-in shaft has two rectangular hardened keys welded to it which slide in the guide tube slot. Thus, as the levering-in shaft is rotated, the guide tube and nut also rotate.

As the breaker is levered in by clockwise rotation, the keys on the levering-in shaft move toward the end of the guide tube slot. As the rear key comes out of the slot, the levering-in shaft turns freely and the breaker moves no further.

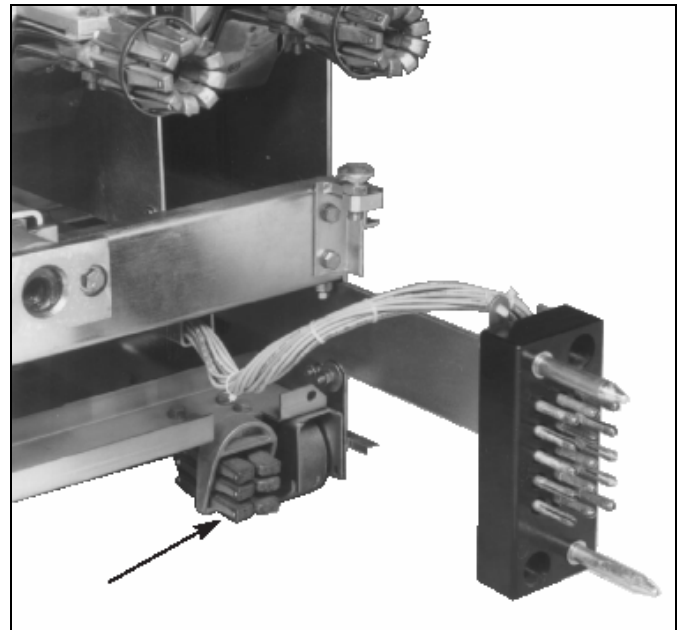

Figure 5-16 DHP-VR Breaker Ground Contact

The end of the guide tube is shaped like a steep-pitch one-turn screw thread so that when the levering shaft is rotated counter-clockwise, the rear key will catch and enter the slot and rotate the guide tube and nut, withdrawing the breaker. At the end of the travel, the nut disengages from the screw and is spin free.

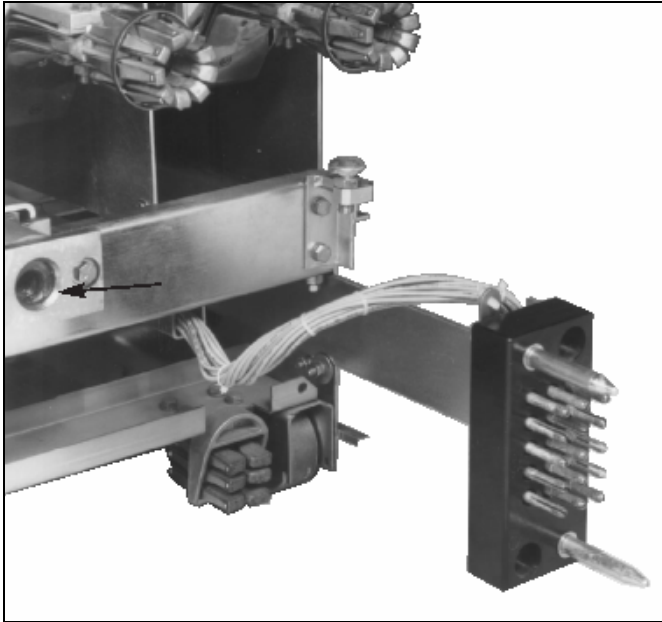

Figure 5-17 DHP-VR Breaker (5 kV) Levering-in Device Nut Housing

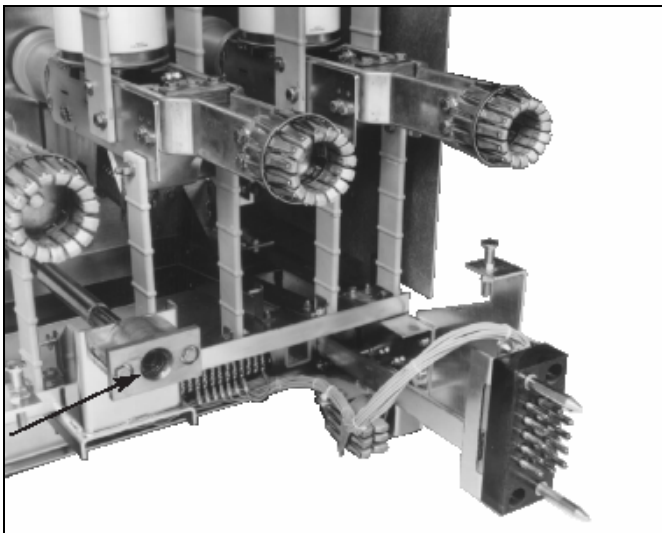

Figure 5-18 DHP-VR Breaker (7.5 and 15 kV) Levering-in Device Nut Housing

SECTION 6: INSPECTION AND MAINTENANCE

6-1 INTRODUCTION



WARNING

- DO NOT WORK ON A BREAKER IN THE "CONNECTED" POSITION.
- DO NOT WORK ON A BREAKER WITH SECONDARY DISCONNECTS ENGAGED.
- DO NOT WORK ON A BREAKER WITH SPRINGS CHARGED OR CONTACTS CLOSED.
- DO NOT DEFEAT ANY SAFETY INTERLOCKS.
- DO NOT LEAVE MAINTENANCE TOOL IN THE SOCKET AFTER CHARGING THE CLOSING SPRINGS

- DO NOT STAND LESS THAN ONE METER AWAY FROM THE BREAKER WHEN TESTING FOR VACUUM INTEGRITY.
- FAILURE TO FOLLOW ANY OF THESE INSTRUCTIONS MAY CAUSE DEATH, SERIOUS BODILY INJURY, OR PROPERTY DAMAGE. SEE SECTION 2-SAFE PRACTICES FOR MORE INFORMATION.

6-2 FREQUENCY OF INSPECTION

Inspect the breaker every 12 to 18 months when operating in a clean, non corrosive environment. For a dusty and corrosive environment, inspection should be performed twice a year. Additionally, it is recommended to inspect the breaker every time it interrupts fault current.

Refer to the table on following page for maintenance and inspection check points.

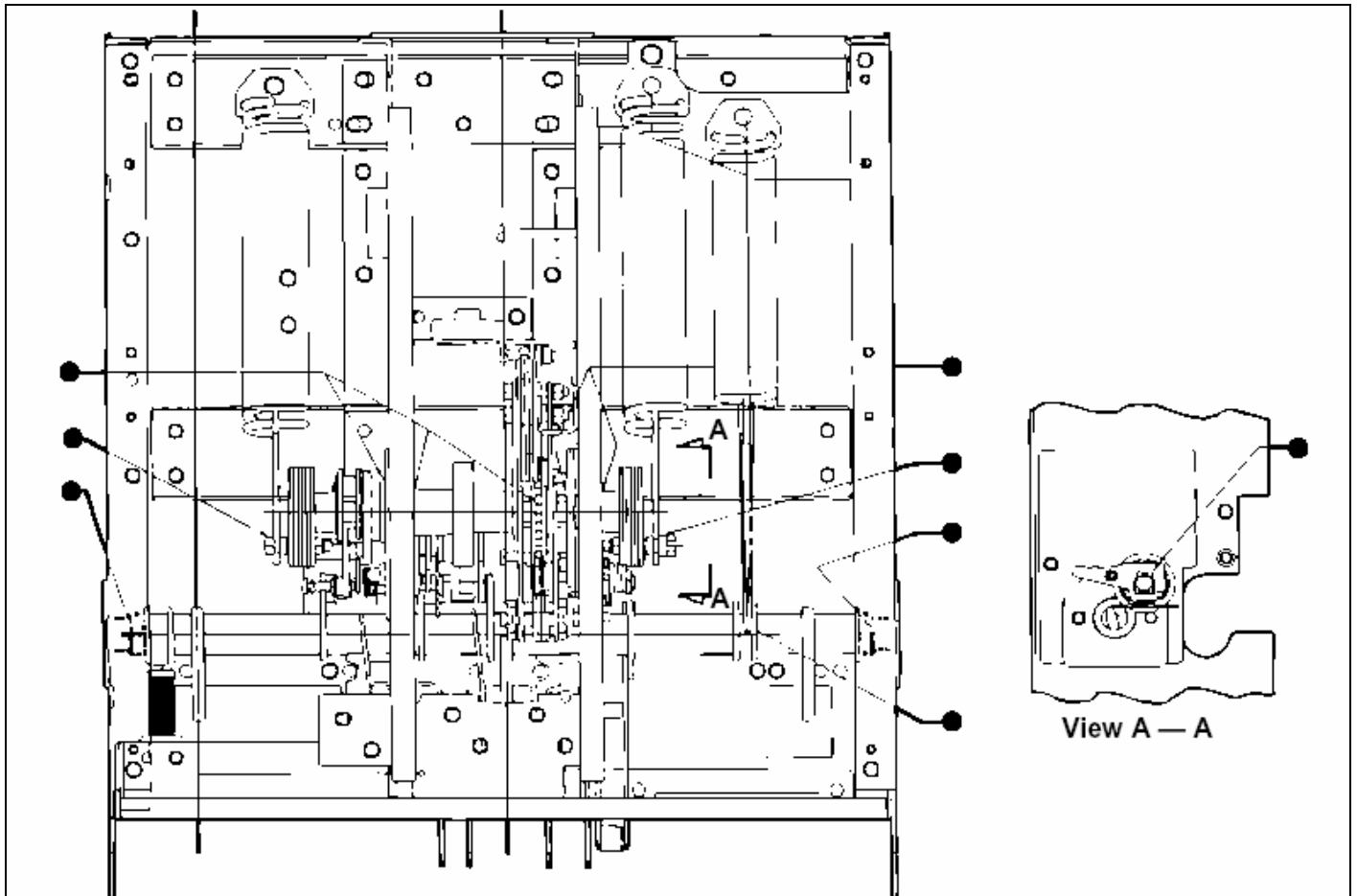

Figure 6-1 Lubrication Points

6-3 INSPECTION AND MAINTENANCE PROCEDURES

No./Section	Inspection Item	Criteria	Inspection Method	Corrective Action if Necessary	
1. Insulation	Stand off insulators, operating rods, tie-bars and barriers	No dirt	Visual check	Clean with lint-free cloth.	
		No cracking	Visual check	Replace cracked unit	
	Insulation Integrity	Main Circuit to Ground	Withstand 27 kV, 60 Hz for 1 minute.	Hipot Tester	Clean and retest or replace.
		Between Main Circuit Terminals.	Withstand 15 kV, 60 Hz for 1 minute. (5kV Ratings) 27kV, 60 Hz for 1 minute. (15kV Ratings)	Hipot Tester	Clean and retest or replace.
	Control Circuit to Ground.	Withstand 1125 V, 60 Hz for 1 minute.	Hipot Tester	Clean and retest or replace.	
2. Power Elements	Vacuum Interrupters	Contact Erosion visibility of mark.	Visual-Close the breaker and look for green mark on moving stem from the rear of the breaker (see Fig. 6.2 & 6.3).	If mark is not visible, replace interrupter assembly. Tighten if necessary	
		VI fixed/moving stem bolts	Visual check for tightness	Replace VI assembly.	
		Contact wipe visible.	Visual (Fig. 6.4 and 6.5)	Replace interrupter assembly if vacuum is not adequate.	
		Adequate Vacuum	See Section 6.4		
		Dirt on ceramic body.	Visual check	Clean with dry lint-free cloth.	
	Primary Disconnects	No burning or damage	Visual check	Replace if burned, damaged or eroded.	
3. Control Circuit Parts	Closing and tripping devices including disconnects.	Smooth and correct operation by control power.	Test closing and tripping of the breaker twice.	Replace any defective device-Identify per troubleshooting chart.	
	Wiring	Securely tied in proper place.	Visual check	Repair or tie as necessary	
	Terminals	Tight	Visual check	Tighten or replace if necessary.	
	Motor	At-5000 Operations	Check Counter	Replace brushes.	
	Tightness of hardware.	No loose or missing parts.	Visual and tightening with appropriate tools.	Tighten or reinstate if necessary.	
4. Operating Mechanism	Dust or foreign matter.	No dust or foreign matter.	Visual check	Clean as necessary.	
	Lubrication	Smooth operation and no excessive wear.	Sight and feel.	Lubricate very sparingly with mineral oil.	
	Deformation or excessive wear.	No excessive deformation or wear.	Visual and operational.	Remove cause and replace parts.	
	Manual operation.	Smooth operation.	Manual charging closing and tripping.	Correct per trouble-shooting chart if necessary.	
	CloSure test	> 0.6 inch over travel	CloSure test 6-9.1	If < 0.6 contact P.I.C. at 412-787-6518	

Bolt Size	8-32	10-32	.25-20	.31-18	.38-16	.50-13
Torque Lb. In.	24	36	72	144	300	540

6-4 VACUUM INTERRUPTER INTEGRITY TEST

Vacuum interrupters used in Type DHP-VR Vacuum Circuit Breaker Elements are highly reliable interrupting elements. Satisfactory performance of these devices is dependent upon the integrity of the vacuum in the interrupter and the internal dielectric strength. Both of these parameters can be readily checked by a one minute ac high potential test. Refer to Table 6.1 for the appropriate test voltage. During this test, the following warning must be observed:



WARNING

APPLYING ABNORMALLY HIGH VOLTAGE ACROSS A PAIR OF CONTACTS IN VACUUM MAY PRODUCE X - RADIATION. THE RADIATION MAY INCREASE WITH THE INCREASE IN VOLTAGE AND/OR DECREASE IN CONTACT SPACING. X-RADIATION PRODUCED DURING THIS TEST WITH RECOMMENDED VOLTAGE AND NORMAL CONTACT SPACING IS EXTREMELY LOW AND WELL BELOW MAXIMUM PERMITTED BY STANDARDS. HOWEVER, AS A PRECAUTIONARY MEASURE AGAINST POSSIBILITY OF APPLICATION OF HIGHER THAN RECOMMENDED VOLTAGE AND/OR BELOW NORMAL CONTACT SPACING, IT IS RECOMMENDED THAT ALL OPERATING PERSONNEL STAND AT LEAST FOUR METERS AWAY IN FRONT OF THE BREAKER ELEMENT.

With the breaker element open, connect all top primary studs (bars) together and the high potential machine lead. Connect all bottom studs together and ground them along with the breaker frame. Start the machine at zero potential, increase to appropriate test voltage and maintain for one minute.

A successful withstand indicates that all interrupters have satisfactory vacuum level. If there is a breakdown, the defective interrupter or interrupters should be identified by an individual test and replaced before placing the breaker in service.



WARNING

AFTER THE HIGH POTENTIAL IS REMOVED, AN ELECTRICAL CHARGE MAY BE RETAINED BY THE VACUUM INTERRUPTERS. FAILURE TO DISCHARGE THIS RESIDUAL ELECTROSTATIC CHARGE COULD RESULT IN AN ELECTRICAL SHOCK. ALL SIX PRIMARY TERMINALS AND THE CENTER RING OF EACH VACUUM INTERRUPTER OF THE CIRCUIT BREAKER SHOULD BE GROUNDED TO REDUCE THIS ELECTRICAL CHARGE BEFORE COMING IN CONTACT WITH THE PRIMARY CIRCUIT.

To avoid any ambiguity in the ac high potential test due

to leakage or displacement (capacitive) current, the test unit should have sufficient volt-ampere capacity. It is recommended that the equipment be capable of delivering 25 milliamperes for one minute.

Although an ac high potential test is recommended, a dc test may be performed if only a dc test unit is available. In this case the equipment must be capable of delivering 5 milliamperes for one minute. When a DC test voltage is used, a high field emission current from a microscopic sharp spot on one contact can be misinterpreted as a sign of a vacuum interrupter filled with air. To avoid a misinterpreted test result, the open interrupter should always be subjected to both voltage polarities. That is, apply the DC voltage:

- first, so that one contact of the interrupter is the cathode, and
- second, so that the other contact of the interrupter is the cathode.

A bad interrupter filled with air will have a similarly high leakage current in both polarities. A good interrupter with a good vacuum level may still have a high leakage current, but this will generally be in only one polarity. Such an interrupter usually has a tiny sharp spot on one contact that produces a high field emission current when the sharp spot is a cathode, but not on an anode. In addition, such an interrupter would also normally withstand the required AC voltage which is the definitive test of its vacuum integrity.

Table 6.1

Breaker Rated Maximum Voltage	Vaccum Interrupter Integrity Test Voltage	
	ac 60 HZ	dc
Up to and including 15.0KV	27 KV	40KV

6-5 CONTACT EROSION AND WIPE

Since the contacts are contained inside the interrupter, they remain clean and require no maintenance. However, during high current interruptions there may be a minimal amount of erosion from the contact surfaces. Maximum permitted erosion is 1/8 inch. To determine contact erosion, close the breaker and observe the vacuum interrupter moving stem from the rear of the breaker. If the mark on each stem is visible, erosion has not reached maximum value thus indicating satisfactory contact surface of the interrupter. If the mark is not visible, the vacuum interrupter assembly must be replaced (Figures 6-2 and 6-3).

The adequacy of contact wipe can be determined by simply observing the vacuum interrupter side of the operating rod assembly on a closed breaker. Figures 6-4 and 6-5 show the procedure for determining the contact wipe. If the wipe is not adequate, the vacuum interrupter assembly (Pole Unit) must be replaced. Field adjustment is not possible.



Figure 6-2 Vacuum Interrupter Showing Contact Erosion Indicator With Breaker Open (Shown here for clarity purposes only)

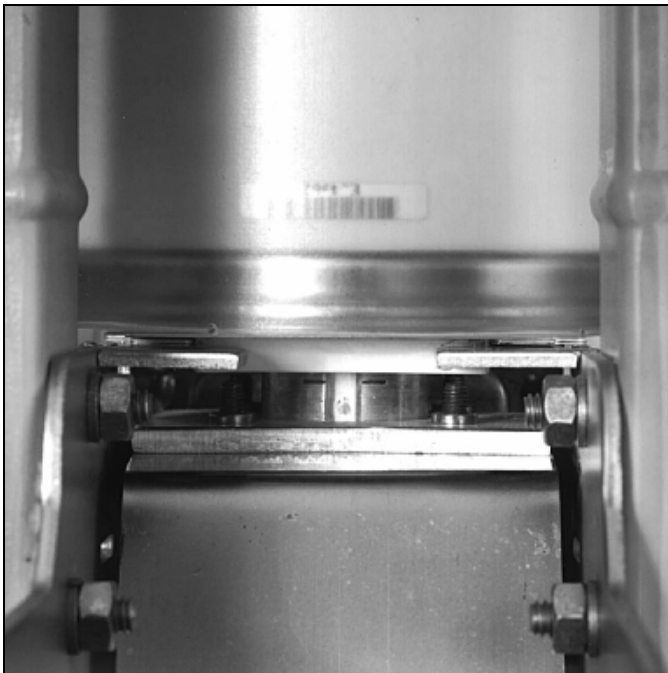

Figure 6-3 Vacuum Interrupter Showing Contact Erosion Indicator With Breaker Closed (Indicators are checked only when breaker is closed)



WARNING

FAILURE TO REPLACE A VACUUM INTERRUPTER ASSEMBLY WHEN CONTACT EROSION MARK IS NOT VISIBLE OR WIPE IS UNSATISFACTORY, WILL CAUSE THE BREAKER TO FAIL TO INTERRUPT AND THEREBY CAUSE PROPERTY DAMAGE OR PERSONAL INJURY.

6-6 INSULATION

In DHP-VR breakers, insulation maintenance primarily consists of keeping all insulating surfaces clean. This can be done by wiping off all insulating surfaces with a dry lint free cloth or dry paper towel. In case there is any tightly adhering dirt that will not come off by wiping, it can be removed with a mild solvent or distilled water. But be sure that the surfaces are dry before placing the breaker in service. If a solvent is required to cut dirt, use Stoddard's Solvent Cutler-Hammer 558 12CA or commercial equivalent. Secondary control wiring requires inspection for tightness of all connections and damage to insulation.

6-7 INSULATION INTEGRITY CHECK

PRIMARY CIRCUIT:

The integrity of primary insulation may be checked by the AC high potential test. The test voltage depends upon the maximum rated voltage of the breaker. For the breakers rated 4.76 kV, 8.25 kV and 15 kV, the test voltages are 15 kV, 27 kV and 27 kV RMS, 60 Hz respectively. Conduct the test as follows:

Close the breaker. Connect the high potential lead of the test machine to one of the poles of the breaker. Connect the remaining poles and breaker frame to ground. Start the machine with output potential at zero and increase to the test voltage. Maintain the test voltage for one minute. Repeat for the remaining poles. Successful withstand indicates satisfactory insulation strength of the primary circuit.

If a DC high potential machine is used, make certain that the peak voltage does not exceed the peak of the corresponding AC RMS test voltage.

SECONDARY CIRCUIT:

Isolate the motor by pulling apart the two insulated quick disconnecting terminals in the two motor leads provided for this purpose. Connect all points of the secondary disconnect pins with a shooting wire. Connect this wire to the high potential lead of the test machine. Ground the

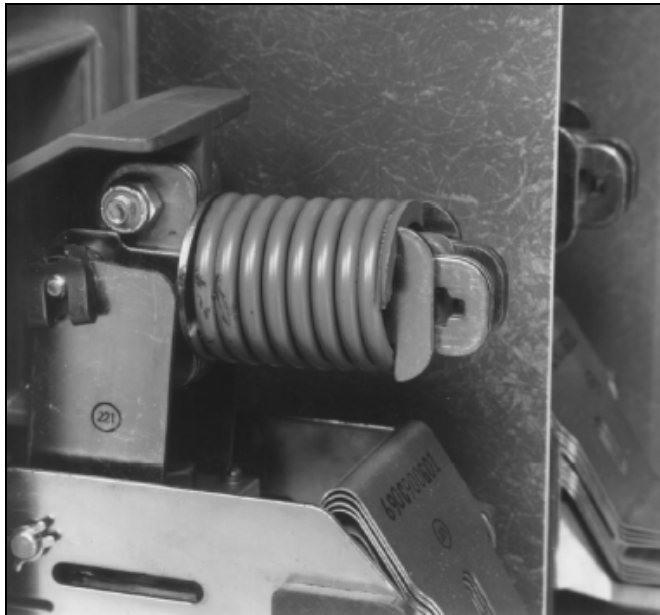

Figure 6-4 "T" Contact Wipe Indicator Example with Blue Spring (if the "T" or any portion of it is visible as shown with the breaker closed, the wipe is satisfactory, See Next Figure for Graphic of All Possibilities)

minute. Successful withstand indicates satisfactory insulation strength of the secondary control circuit. Remove the shooting wire and reconnect the motor leads.

6-8 PRIMARY CIRCUIT RESISTANCE CHECK

Since the main contacts are inside the vacuum chamber they remain clean and require no maintenance at any time. Unlike most typical circuit breaker designs, DHPVR breakers do not have sliding contacts at the moving stem either. Instead they use a highly reliable and unique flexible clamp design that eliminated the need for lubrication and inspection for wear.

If desired, the DC resistance of the primary circuit may be measured as follows: close the breaker, pass at least 100 amps DC current through the breaker. With the low resistance instrument, measure resistance across the studs on the breaker side of the disconnects for each pole. The resistance should not exceed 60, 40, 20 microohms for 1200, 2000, and 3000 amps respectively.

6-9 MECHANISM CHECK

Make a careful visual inspection of the mechanism for any loose parts such as bolts, nuts, pins, rings, etc. Check for excessive wear or damage to the breaker components. Operate the breaker several times manually and electrically. Check the closing and opening times to verify that they are in accordance with the limits in Table 5.1.

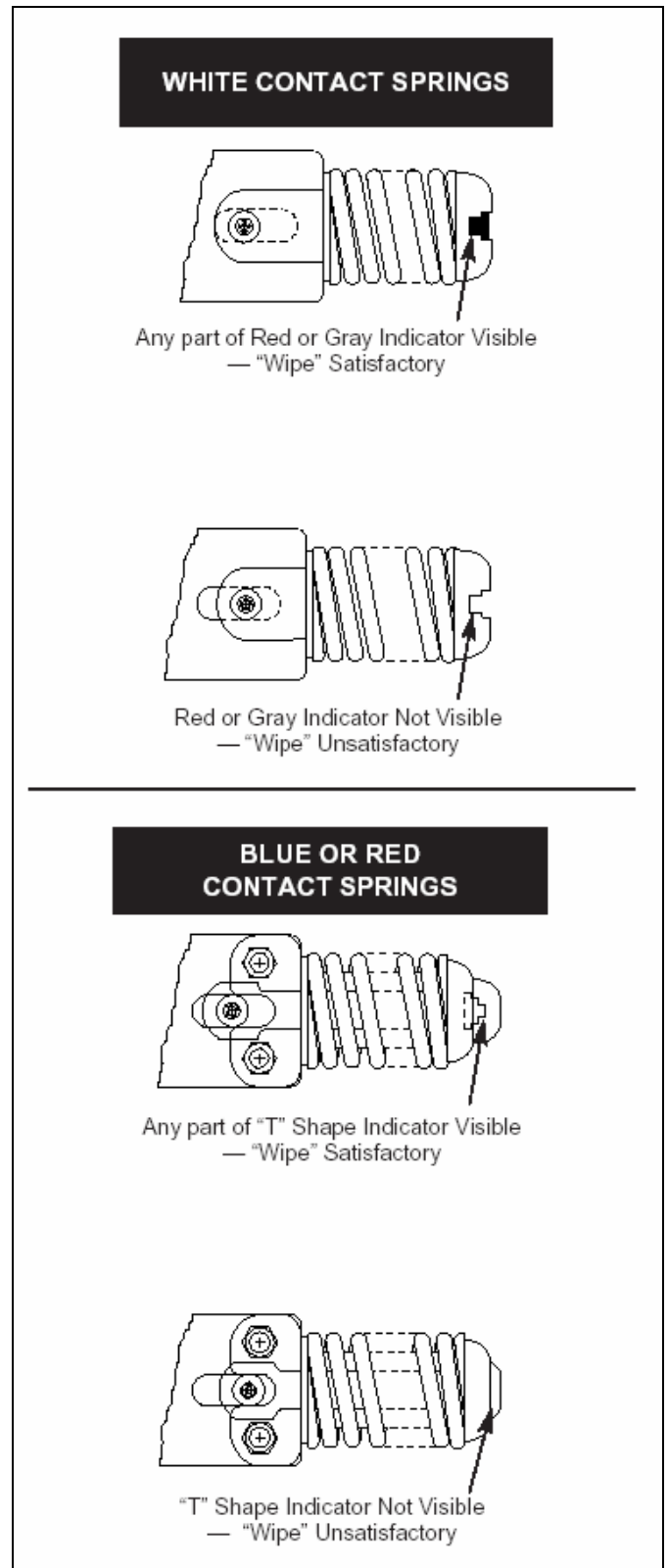

Figure 6-5 Wipe Indication Procedure (Performed Only with Breaker Closed)

6-9.1 CLOSURE™ TEST

Introduction: The CloSure™ Test is a simple yet extremely effective means to determine and monitor the ability of the mechanism to close the breaker contacts fully. It provides a quantitative measure of the extra energy available in terms of over travel in inches to close the breaker contacts to their full extent. It may be used periodically to monitor the *health* of the mechanism.

General Information: The CloSure™ Test can be performed on the VCP-W, VCP-WR, VCPW-ND, DHP-VR, W-VACR, and W-VAC lines of vacuum circuit breakers. Refer to Table 6.4 for a list of circuit breakers. If the CloSure™ travel obtained is as specified, the mechanism performance is satisfactory. If the CloSure™ travel does not conform as shown in Figure 6-19, contact Cutler-Hammer for further information. (See Step 13).



WARNING

DO NOT ATTEMPT TO INSTALL OR PERFORM MAINTENANCE OR TESTS ON THE EQUIPMENT WHILE IT IS ENERGIZED. NEVER PUT YOUR HANDS NEAR THE MECHANISM WHEN THE CIRCUIT BREAKER IS IN THE CHARGED OR CLOSED POSITION. DEATH OR SEVERE PERSONAL INJURY CAN RESULT FROM CONTACT WITH ENERGIZED EQUIPMENT. ALWAYS VERIFY THAT NO VOLTAGE IS PRESENT BEFORE PROCEEDING WITH THE TASK, AND ALWAYS FOLLOW GENERALLY ACCEPTED SAFETY PROCEDURES.

Safety Precautions: Read and understand these instructions before attempting any maintenance, repair or testing on the breaker. The user is cautioned to observe all recommendations, warnings and cautions relating to the safety of personnel and equipment.

The recommendations and information contained herein are based on Cutler-Hammer experience and judgment, but should not be considered to be all-inclusive or covering every application or circumstance which may arise. If further information is required, you should consult Cutler-Hammer.

Testing Procedures: Assuming that the breaker is safely pulled out to the Test/Disconnect position in the enclosure or placed on the workbench, follow this procedure to perform the CloSure™ Test using Kit Style# 6352C58G01. For further instructions on disconnecting the circuit breaker consult Section 4 of this manual. If the enclosure is equipped with the MOC operating in the

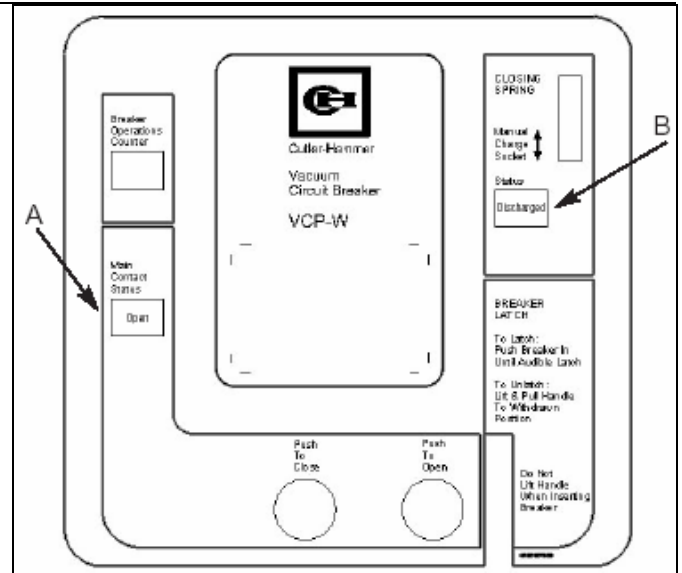

Figure 6-6 Status Indicators (“A” shows the contact status indication and “B” shows the spring indication.)

test position also, make certain that the MOC is connected to operate.

Step 1 - On the front cover identify the status indicators. MAKE SURE THE CLOSING SPRING STATUS INDICATES “Discharged” AND THE MAIN CONTACT INDICATOR SHOWS “Open” (Figure 6-6).

Step 2 - Remove the circuit breaker front cover. **Be sure**

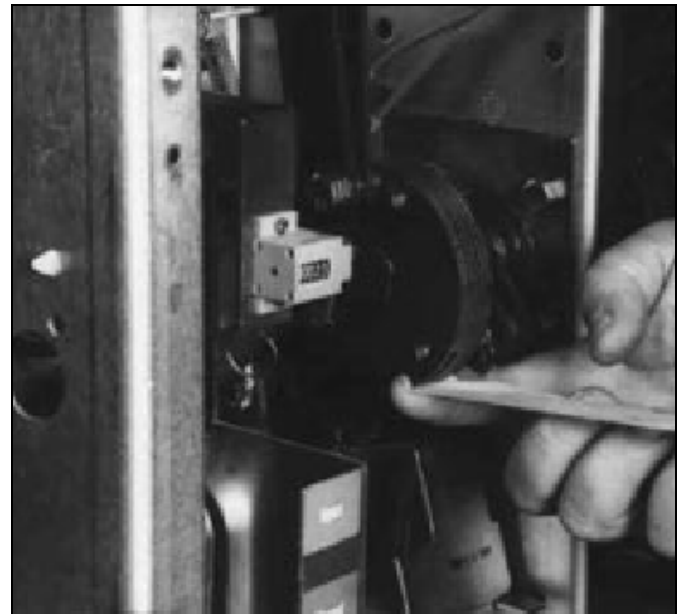

Figure 6-7 Starting Tape at Bottom of Cam

to save the original fasteners for re-assembly.

Step 3 - Cut a piece of one inch wide drafting/masking tape approximately 8 to 10 inches long.

Step 4 - Place the tape around the cam starting from the bottom up. Make certain that the tape adheres well to the cam surface. (See Figures 6-7, 6-8 and 6-9).

Step 5 - Mount the transparent CloSure™ Test Tool with two bolts and washers. Refer to Figures 6-20, 6-21 and Table 6.4 for appropriate mounting holes. Hand tighten the bolts (Figures 6-10, 6-11, 6-20 and 6-21).

Step 6 - A Sanford® Sharpie® black fine point permanent marker, item no. 30001, is recommended for this next step. Place the marker tip in the proper hole ("C"). Refer to Figure 6-20 and make a heavy mark on the tape as shown in Figure 6-13.

Step 7 - Charge the closing springs with the maintenance tool. Continue charging the closing springs until a "click" is heard and the status indicator shows "Charged" (Figure 6-12).

Step 8 - While holding the marker tip on the tape, close the breaker (Figure 6-13).

Step 9 - Move the marker back and forth horizontally approximately 15° in both directions to create a line on the tape that identifies the closed rest position (Figures 6-14, 6-20 and 6-16).

Step 10 - Remove the marker from hole "C".

Step 11 - Push the "push to open" clapper to open the circuit breaker.

Step 12 - Inspect the circuit breaker to assure it is in the

open position and the closing springs are discharged. Remove the transparent CloSure™ Tool. Remove the tape from the cam and stick the tape on the front right side sheet of the circuit breaker. Record the date of the test and the operations counter reading on the tape (Figures 6-17 and 6-18 and 6-19).

Step 13 - Evaluate the CloSure™ performance by comparing the test tape with the illustrations in Figure 6-19. If the marking is similar to 6-19A, measure the over travel "x": If "x" is greater than or equal to 0.6 inches, the circuit breaker performance is satisfactory. If "x" is less than 0.6 inches or if the marking is similar to 6-19B or 6-19C, immediately contact the Product Integrity Center for Technical Support at (412) 787-6518.

Step 14 - Remove the CloSure™ Tool. Reassemble the front cover onto the circuit breaker. Return the circuit breaker to its original configuration and setup

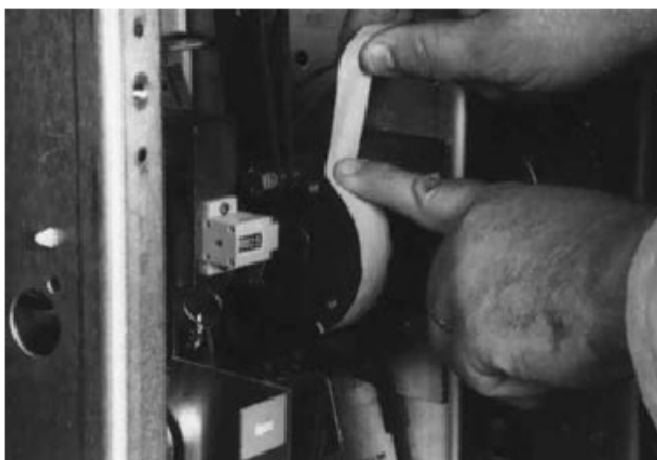

Figure 6-8 Wrapping Tape Up Around Cam



Figure 6-9 Attaching Tape Around Side of the Cam



Figure 6-10 Attaching CloSure™ Test Tool at Hole "A"

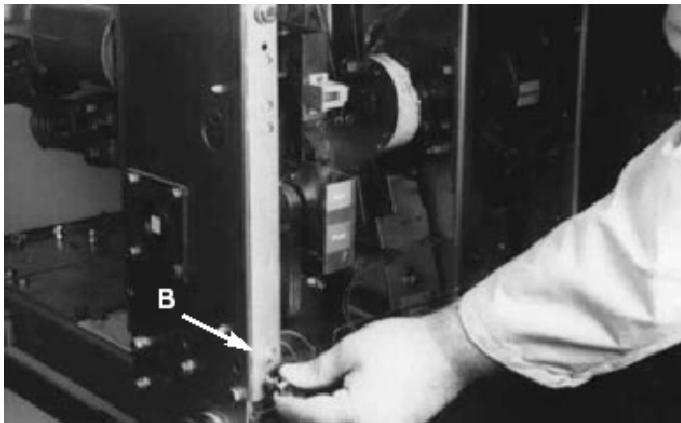

Figure 6-11 Attaching CloSure™ Test Tool at Hole "B"

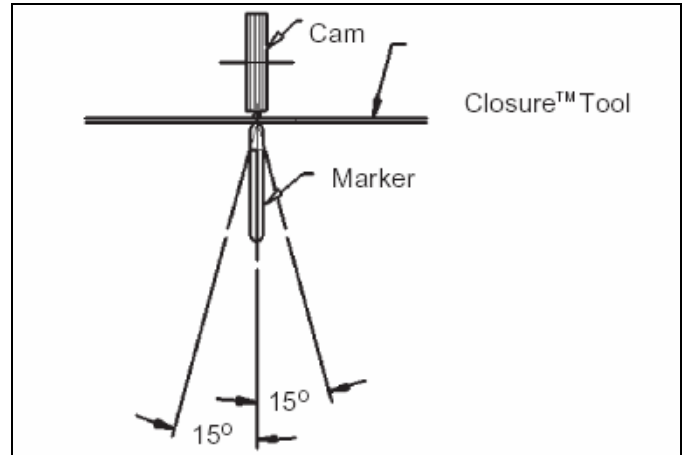

Figure 6-14 Top View of Cam and Marker Interface

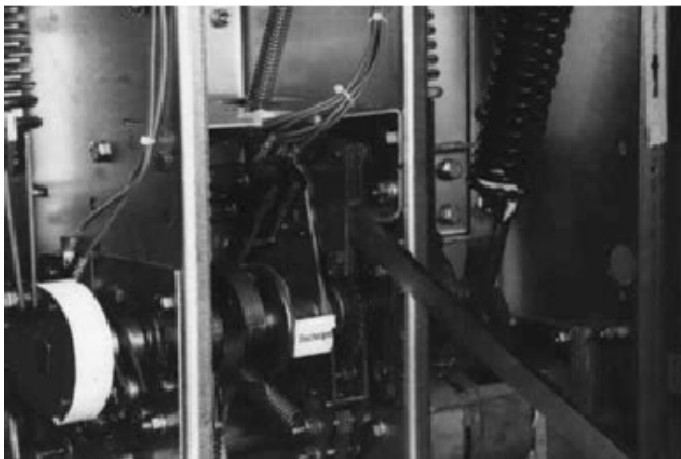

Figure 6-12 Manually Charging Closing Springs

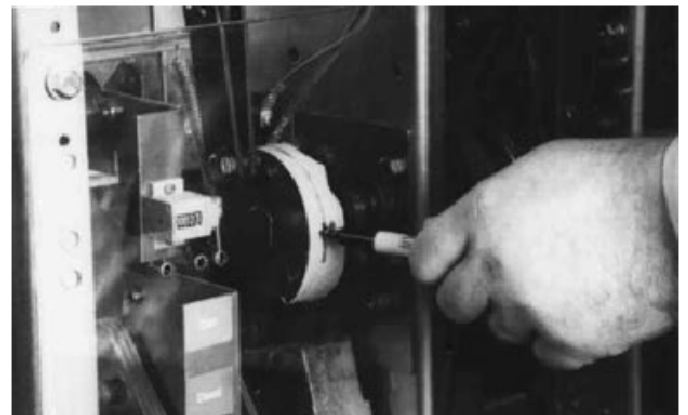

Figure 6-15 Move Marker 15° to Right

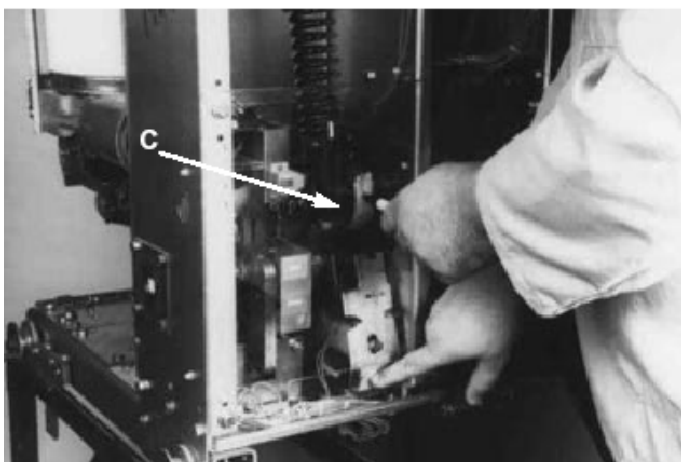

Figure 6-13 Manually Closing Circuit Breaker with Marker in Hole "C".

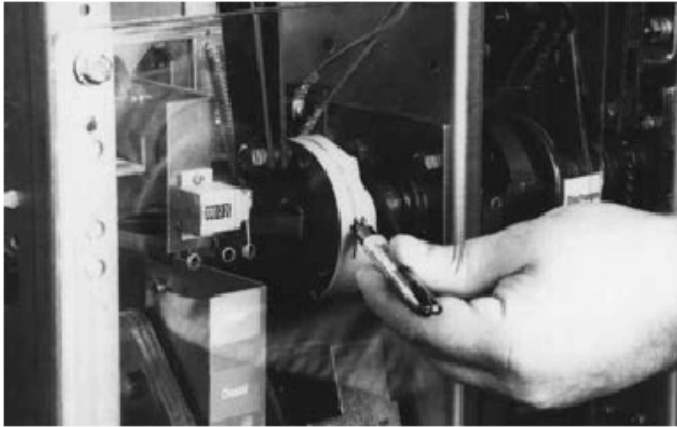

Figure 6-16 Move Marker 15_o to left



Figure 6-17 Remove Marked Masking Tape from Cam



Figure 6-18 Place Tape on Right Side Panel of Breaker

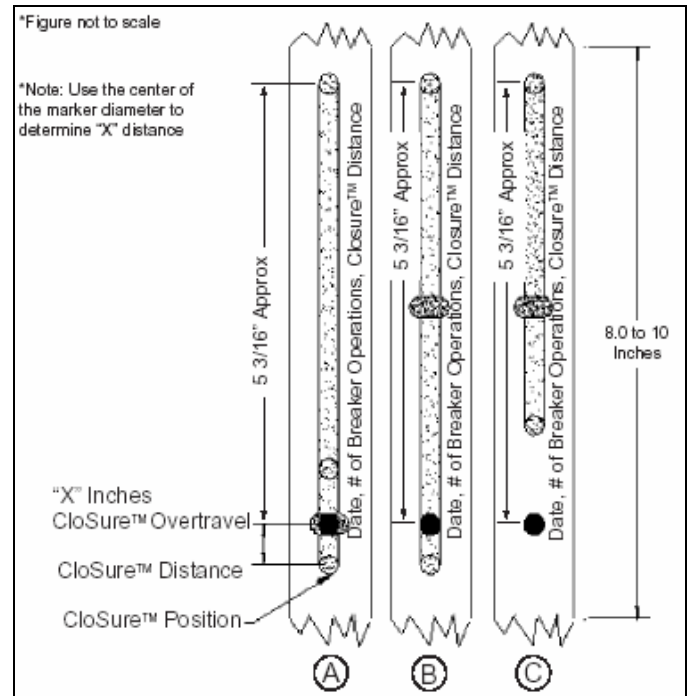

Figure 6-19 Illustrative Testing Tape Sample

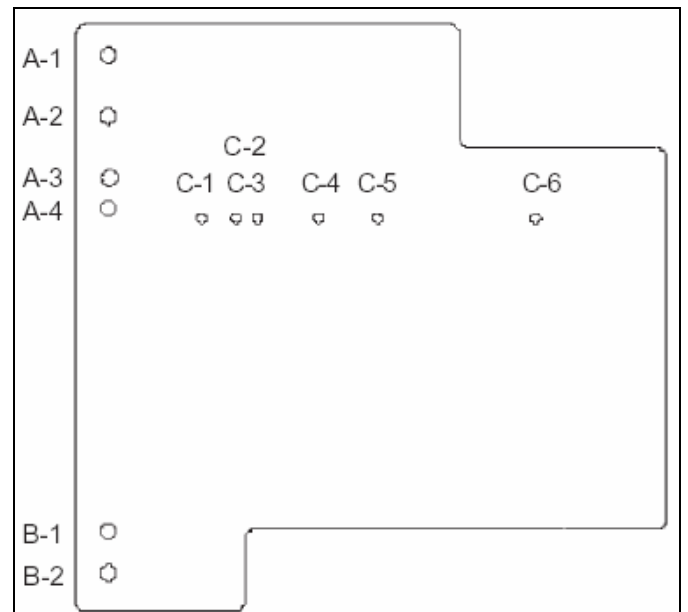

Figure 6-20 Front View of CloSure™ Tool Showing Mounting/Testing Hole Locations (6352C49H01)

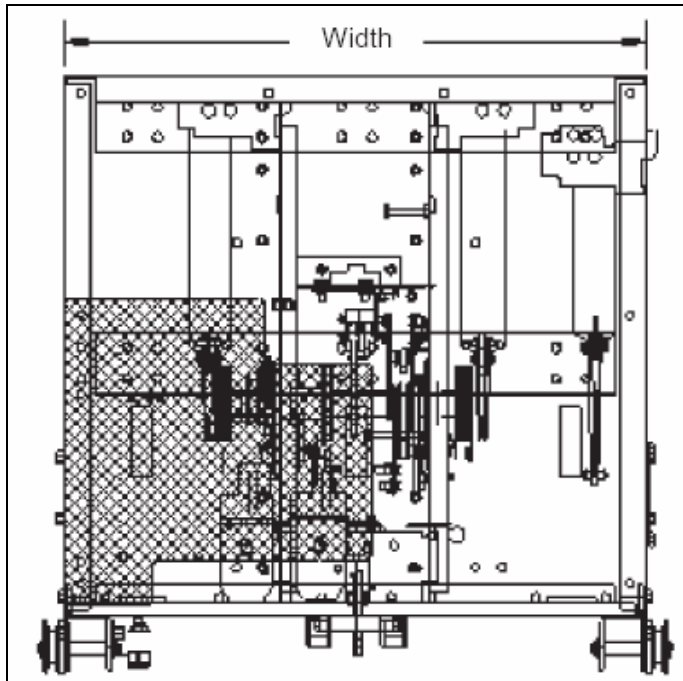

Figure 6-21 Typical Circuit Breaker Front View with CloSure™ Tool Attached (approximate mechanism chassis width)

Breaker Line	Approximate Mechanism Cabinet Width (inch)	Upper Mounting Hole	Lower Mounting Hole	Marker Placement Hole
DHP-VR	20	A1	B2	C2
	29	A1	B1	C5
VCPW-ND	20/21	A1	B2	C2
VCP-W	29	A1	B2	C5
	33	A2	B2	C6
VVP-WG, VCP-WGR	29	A1	B2	C5
VCP-WR	18	A1	B2	C1
	20	A1	B2	C2
	29	A1	B2	C5
W-VAC, W-VACR	18	A1	B2	C1
	25	A1	B1	C4
	33	A2	B2	C6

Table 6.4 Closure™ Tool Mounting/Testing Locations by Circuit Breaker Type

6-10 LUBRICATION

All parts that require lubrication have been lubricated during the assembly with molybdenum disulphide grease (Cutler-Hammer Material No. 5370 1QB). Over a period of time, this lubricant may be pushed out of the way or degrade. Proper lubrication at regular intervals is essential for maintaining the reliable performance of the mechanism. Every 12 to 18 months or every 2000 operations, whichever comes first, the circuit breaker should be relubricated. The locations shown in Figure 6-1 should be lubricated with a drop of light machine oil.

After lubrication, operate the circuit breaker several times manually and electrically.

Roller bearings are used on the pole shaft, the cam shaft, the main link and the motor eccentric. These bearings are packed at the factory with a top grade slow oxidizing grease which normally should be effective for many years. They should not be disturbed unless there is definite evidence of sluggishness, dirt or parts are dismantled for some reason.

If it becomes necessary to disassemble the mechanism, the bearings and related parts should be thoroughly cleaned. Remove old grease in a good grease solvent. Do not use carbon tetrachloride. They should then be washed in light machine oil until the cleaner is removed. After the oil has been drawn off, the bearings should be packed with Cutler-Hammer Grease 53701QB or equivalent.

6-11 TROUBLESHOOTING CHART (CONTINUED ON NEXT PAGE)

SYMPTOM	INSPECTION AREA	PROBABLE DEFECTS
FAILS TO CLOSE		
<ul style="list-style-type: none"> • Closing Springs not charged 	<ul style="list-style-type: none"> • Control Circuit 	<ul style="list-style-type: none"> • Control Power (Fuse blown or switch off) • Secondary Disconnects • Motor Cut-off Switch (Poor or burned contacts. Lever not operational.) • Terminals and connectors (Poor or burned contacts) • Motor (Brushes worn or commutator segment open)
	<ul style="list-style-type: none"> • Mechanism 	<ul style="list-style-type: none"> • Pawls (Slipping or broken) • Ratchet Wheel (Teeth worn or broken) • Cam Shaft Assy. (Sluggish or jammed) • Oscillator (Reset spring off or broken)

SYMPTOM	INSPECTION AREA	PROBABLE DEFECTS
FAILS TO CLOSE		
<ul style="list-style-type: none"> Closing Springs Charged but breaker does not close 	<ul style="list-style-type: none"> No Closing Sound (Close Coil does not pick up) 	<ul style="list-style-type: none"> Control Power (Fuse blown or switch off) Secondary Disconnects Anti Pump Relay (Y relay N.C. contact open or burned or relay picks up) Close Coil (Open or burned) Latch Check Switch (Contact open - Bad switch or trip bar not reset) Auxiliary Switch (b contact open or burned) Motor Cut-off (Contacts open or burned) Trip Coil Assy. (Clapper fails to reset)
	<ul style="list-style-type: none"> Closing Sound But no Close 	<ul style="list-style-type: none"> Pole Shaft (Not open fully) Trip Latch Reset Spring (Damaged or missing) Trip Bar-D Shaft (Fails to remain reset) Trip Latch-Hatchet (Fails to remain reset) Trip Floor Tripper (Fails to remain reset) Close Latch (Binding) Close Latch Roller (Binding) Trip Circuit Energized
UNDESIRABLY CLOSES		
	<ul style="list-style-type: none"> Control Circuit 	<ul style="list-style-type: none"> Close Circuit (CS/C Getting shorted)
	<ul style="list-style-type: none"> Mechanism 	<ul style="list-style-type: none"> Close Release Latch (Fails to reset) Close Floor Tripper (Fails to reset)

SYMPTOM	INSPECTION AREA	PROBABLE DEFECTS
FAILS TO TRIP		
<ul style="list-style-type: none"> No Trip Sound 	<ul style="list-style-type: none"> Control Circuit Trip Mechanism 	<ul style="list-style-type: none"> Control Power (Fuse blown or switch off) Secondary Disconnect Auxiliary Switch (a contact not making poor or burned) Trip Coil (Burned or open) Terminals and Connections (Poor or burned or open) Trip Clapper (Jammed)
<ul style="list-style-type: none"> Trip Sound But no Trip 	<ul style="list-style-type: none"> Trip Mechanism Vacuum Interrupter (One or more Welded) 	<ul style="list-style-type: none"> Trip Bar, Trip Latch (Jammed) Pole Shaft (Jammed) Operating Rod Assembly (Broken or pins out)
UNDESIRABLY TRIPS		
	<ul style="list-style-type: none"> Control Circuit 	<ul style="list-style-type: none"> Control Power (CS/T Switch, remains made)
	<ul style="list-style-type: none"> Mechanism 	<ul style="list-style-type: none"> Trip Coil Clapper (Not resetting) Trip Bar or Trip Latch (Poor engagement of mating or worn surfaces) Trip Bar Reset Spring (Loss of torque)

SECTION 7: RENEWAL PARTS

7-1 GENERAL

In order to minimize production downtime, it is recommended that an adequate quantity of spare parts be carried in stock. The quantity will vary from customer to customer, depending upon the service severity and continuity requirements. Each customer should develop his own stock level based on operating experience.

7-1.1 ORDERING INSTRUCTIONS

- a. Always specify the breaker rating information and shop order number.
- b. Describe the item, give the style number, and specify the quantity required.
- c. Specify the voltage for electrical components.
- d. Specify the method of shipping desired.
- e. Send all orders or correspondence to the nearest Cutler-Hammer sales office.

Eaton Corporation
Cutler-Hammer business unit
1000 Cherrington Parkway
Moon Township, PA 15108-4312
USA
tel: 1-800-525-2000
www.cutler-hammer.eaton.com



Cutler-Hammer

Effective: March 2007



Cutler-Hammer

© 2003 Eaton Corporation
All Rights Reserved
Printed in USA
Publication No. IB6513C80G (IS)
March 2007