

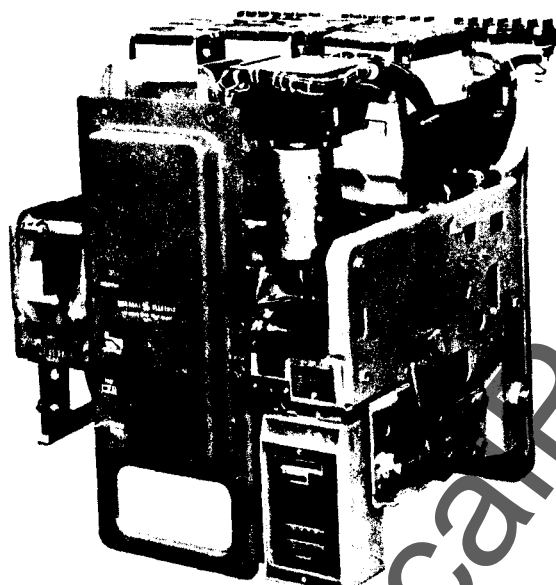

Low Voltage Power Circuit Breakers

Types AKR-30/50 and AKRT-50



A-TYPE DRAWOUT
Electrically Operated

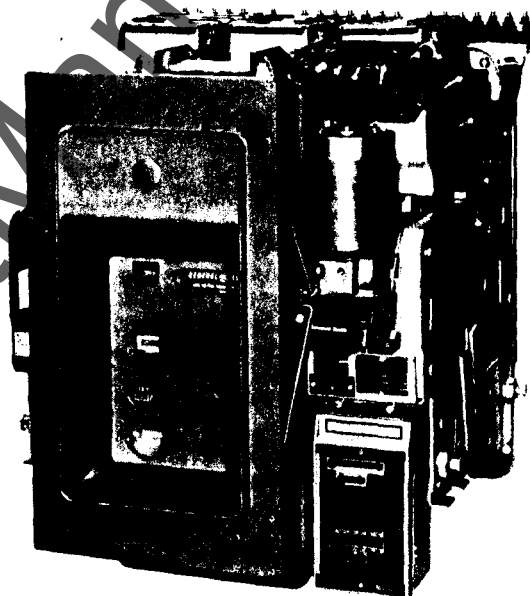

B-TYPE DRAWOUT
Electrically Operated

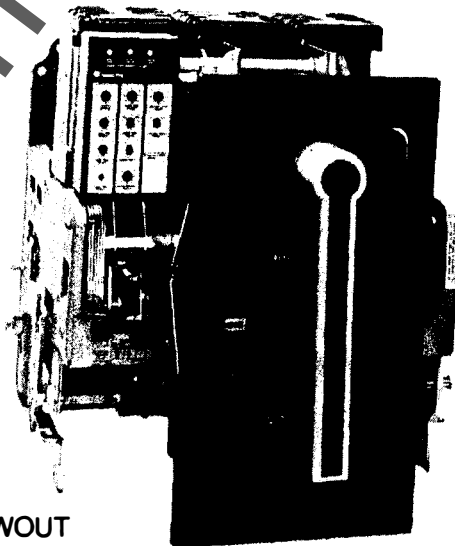

D-TYPE DRAWOUT
Manually Operated



INSTALLATION AND OPERATION AKR/AKRU-30, 50 & AKRT-50 FRAME SIZE LOW-VOLTAGE POWER CIRCUIT BREAKERS

CONTENTS

	Page
INTRODUCTION	3
MOUNTING TYPES	3
RECEIVING, HANDLING AND STORAGE	4
INSTALLATION	4
Location	4
Stationary Breakers	4
Drawout Breakers	4
General	4
Code A (AKD-6 Switchgear)	4
Code B (AKR Substructure)	6
Code D AKD-8 Switchgear	10
Connections	11
OPERATION	12
General	12
Manual Closing	12
Electrical Closing	12
Tripping	13
FUSED BREAKERS	13
MAINTENANCE	13
Inspection	13
Lubrication	13
INTERCHANGEABILITY OF DRAWOUT BREAKERS	14
E-Type Rejection	16
CURRENT RATINGS FOR AUXILIARY DEVICES	20

OTHER PUBLICATIONS

The instructions in this publication are general in nature. For more detailed information on troubleshooting, overhauling or replacing parts, refer to the following:

Maintenance Manual	GEK-64459
Renewal Parts	GEF-4527
EC Trip Devices	GEI-86157
ECS/SST Test Set:	
Cat. TAK-TS2	GEK-73300-1
MicroVersa Trip Test Set:	
Cat. TVTS1	GEK-64464
Time Current Curves	GEZ-4431
Obsolete Test Set for ECS/SST	
Cat. TAK-TS1	GEK-64454

These instructions do not purport to cover all details or variations in equipment nor to provide for every possible contingency to be met in connection with installation, operation or maintenance. Should further information be desired or should particular problems arise which are not covered sufficiently for the purchaser's purposes, the matter should be referred to the General Electric Company.

INTRODUCTION

These instructions describe the installation and operation of the Low Voltage Power Circuit Breakers tabulated below. They cover a variety of models which may differ in rating, trip device and/or mounting type. Each model has a distinctive designation.

MOUNTING TYPES

As listed in Tale 1, the 800 thru 2000A frame AKR breakers are furnished in four different mounting types—drawout A, drawout B, drawout D, and stationary (S). Each of these is described in the text. A breaker's type is indicated on its nameplate; the designation system is explained in Fig. 1.

TABLE 1—BREAKER DESIGNATIONS

FRAME SIZE (Amperes)		DRAWOUT MOUNTING			STATIONARY MOUNTING (CODE S)	NOTES
250V.Dc	600V.Ac 50/60 Hz.	AKD-6 Switchgear (CODE A)	Substructure (1) (CODE B)	Substructure AKD-8 Switchgear (CODE D)		
800	800	AKR-(*)A-30 AKR-(*)A-30H	AKR-(*)B-30 AKR-(*)B-30H	AKR-(*)D-30 AKR-(*)D-30H	AKR-(*)S-30 AKR-(*)S-30H	(2)
2000	1600	AKR-(*)A-50 AKR-(*)A-50H	AKR-(*)B-50 AKR-(*)B-50H	AKR-(*)D-50 AKR-(*)D-50H	AKR-(*)S-50 AKR-(*)S-50H	(2)
—	2000	AKRT-(*)A-50 AKRT-(*)A-50H	AKRT-(*)B-50 AKRT-(*)B-50H	AKRT-(*)D-50 AKRT-(*)D-50H	AKRT-(*)S-50 AKRT-(*)S-50H	(2)
—	800	AKRU-(*)A-30	AKRU-(*)B-30	AKRU-(*)D-30	—	(3)
—	1600	AKRU-(*)A-50	AKRU-(*)B-50	AKRU-(*)D-50	—	(3)
Special Dc Breakers For Field Switching						
800	—	—	AKR-NB-30F	AKR-ND-30F	AKR-NS-30F	
2000	—	—	AKR-NB-50F	AKR-ND-50F	AKR-NS-50F	

- (1) All substructures and AKD-8 breakers employ a deep escutcheon.
- (2) The "H" suffix denotes extended short circuit ratings.
- (3) Integrally fused models.
- (*) This digit identifies the trip device:
 - 2 = EC-1 or EC-2A. Dc only.
 - 4 = ECS
 - 5 = SST 50/60 Hertz only
 - 6 = Micro Versa Trip 50/60 Hertz Only
 - N = Non-automatic. In addition, all non-automatic 250V.Dc breaker types carry the suffix letter D after the frame number, e.g., AKR-NB-50D.

Example: AKR-5B-50 identifies a drawout, substructure-mounted breaker equipped with the SST trip device. The EC trip devices are electro-mechanical. ECS, SST and Micro-Versa Trip units are Solid State.

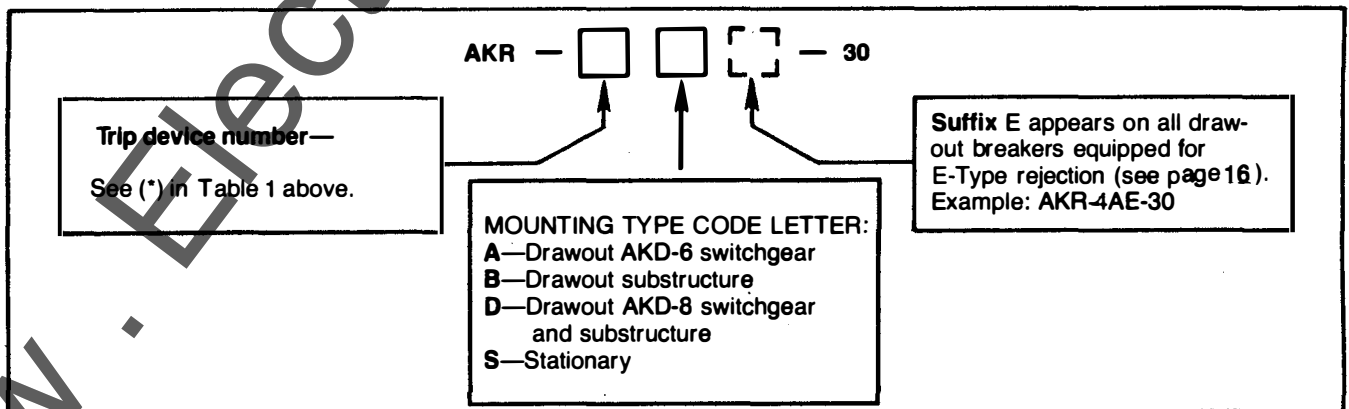

Fig. 1. AKR breaker type designation

RECEIVING, HANDLING AND STORAGE

Before installing or operating these circuit breakers, carefully read these instructions.

Upon receipt of a circuit breaker, immediately examine for any damage or loss sustained in shipment. If injury, loss or rough handling is evident, file a damage claim at once with the transportation company and notify the nearest General Electric Sales Office.

Unpack the circuit breaker as soon as possible after it has been received. Exercise care in unpacking to avoid damage to

the breaker parts. Be sure that no loose parts are missing or left in the packaging material. Blow out any dirt or loose particles of packaging material remaining on or in the breaker.

If the circuit breaker is not to be placed in service at once, store it in a clean, dry location in an upright position. Support it to prevent bending of the studs or damage to any of the breaker parts. Do not cover the breaker with packing or other material which absorbs moisture that may cause corrosion of breaker parts. A covering of kraft or other non-absorbent paper will prevent dust from settling on the breaker.

INSTALLATION

NOTE: Before installing in a Nuclear Class 1E application, determine that this product is intended for such use by checking the procurement records.

LOCATION

In choosing a location for the installation of these breakers there are two factors to be considered. The first is the location's environmental impact on the breaker. Much better performance and longer life can be expected if the area is clean, dry, dust-free and well ventilated. The second is convenience for operation and maintenance. The breaker should be easily accessible to the operator and there should be sufficient space available for maintenance work.

STATIONARY BREAKERS

These breakers are designed for mounting in a switchboard or enclosure designed and constructed by others. Mounting consists of bolting the breaker frame to a supporting structure within the switchboard or enclosure, connecting the power buses or cables, and making any necessary control connections. The front cover of the breaker enclosure may be a hinged door or a plate bolted to the panel, including a cut-out opening through which the front escutcheon of the breaker can protrude.

The surface on which the breaker is mounted must be flat to avoid internal distortion of the breaker. The supporting structure must be rigid enough to avoid any possibility of the breaker studs supporting the weight of the breaker. Minimum cutout dimensions as given by the appropriate outline drawing must be maintained to provide adequate electrical clearance. Connecting bus and cables must be rigidly supported to prevent undue stress on the breaker terminals.

The outline drawings in Table 2 provide basic dimensional information for designing the panel or enclosure mounting.

TABLE 2

Stationary Breaker Type	Outline	
	Manually Operated	Electrically Operated
AKR-()S-30/30H	139C4300	139C4301
AKR-()S-50/50H AKRT-()S-50/50H	139C4761	139C4762

DRAWOUT BREAKERS

GENERAL

Drawout breakers are manufactured in three different styles identified by mounting code letters A, B and D. Code A breakers are employed in AKD-6 switchgear and feature closed-door drawout operation. Code B breakers provide an alternate closed-door drawout arrangement with the stationary element furnished as a preassembled "substructure". Code D breakers are employed in AKD-8 or substructure type gear and feature closed door drawout. The construction and operation of each of these drawout styles is covered under respective headings in the following text.

As a general rule, breakers of the same drawout type, voltage rating and ampere frame size are physically interchangeable. However, to be electrically interchangeable with respect to secondary and control circuits, they must have duplicate wiring. The degree of interchangeability and the mechanisms for controlling it are discussed separately on page (14).

Note: The three drawout types are mutually noninterchangeable; before insertion is attempted, verify that the breaker model matches its intended compartment.

CODE A (AKD-6 SWITCHGEAR) (Fig. 2)

This type drawout breaker is supported by two protruding pins on each side of its frame; these engage slots in telescoping slide rails (tracks) mounted to each sidewall of the breaker compartment. The door of the compartment is hung on a telescoping inner housing also attached to the movable tracks. These elements are arranged so that the door moves in unison with the breaker between the CONNECTED and DISCONNECTED positions, allowing the breaker to be racked without opening the door. This feature is referred to as "closed-door drawout".

The in and out movement of the breaker between the CONNECTED-TEST-DISCONNECTED positions is performed by a breaker-mounted apparatus called the drawout or "racking" mechanism. It comprises a transversely-mounted, jackscrew-driven crankshaft with a slotted crank arm at each end. As the crankshaft is rotated, each crank arm fulcrums about a fixed pin in the compartment to move the breaker in or out.

The jackscrew drives the crankshaft via an internally threaded trunnion supported in a crank centrally located on the crankshaft. The jackscrew is rotated by a removable, externally-operated crank handle (Part No. 193A1990P1) inserted thru an opening in the breaker's escutcheon. Access to this opening is via a sliding cover marked RACKING SCREW.

The drawout operation features four discrete positions:

CONNECTED—This is the breaker's "In-Service" position. It is fully inserted in its compartment; the primary and secondary disconnect contacts are fully engaged. The breaker must be tripped before it can be racked into or out of this position.

TEST—In this position the primary contacts are disconnected but secondary contacts remain engaged. This allows complete breaker operation without energizing the primary circuit.

DISCONNECTED—Both primary and secondary contacts are disengaged.

Breakers can be racked between the above positions with the compartment door closed. Each of the three positions is clearly shown by a rotatory indicator visible through an opening in the door.

WITHDRAWN—With the compartment door open, the breaker can be manually pulled out to the WITHDRAWN position. At this point the tracks are fully extended and the breaker is completely out of its compartment, ready for removal. Note that the racking mechanism is not employed for movement of the breaker between the DISCONNECTED and WITHDRAWN positions.

Breaker Insertion

1. Prior to lifting a breaker to its intended compartment location, observe the following precautions:
 - a. Check the compartment to insure that it is free of foreign objects.
 - b. Verify that the breaker is the correct type for that compartment.
 - c. Insure that the breaker is OPEN.
 - d. Apply a thin, fresh coat of D50HD38 lubricant to the breaker's primary disconnects.

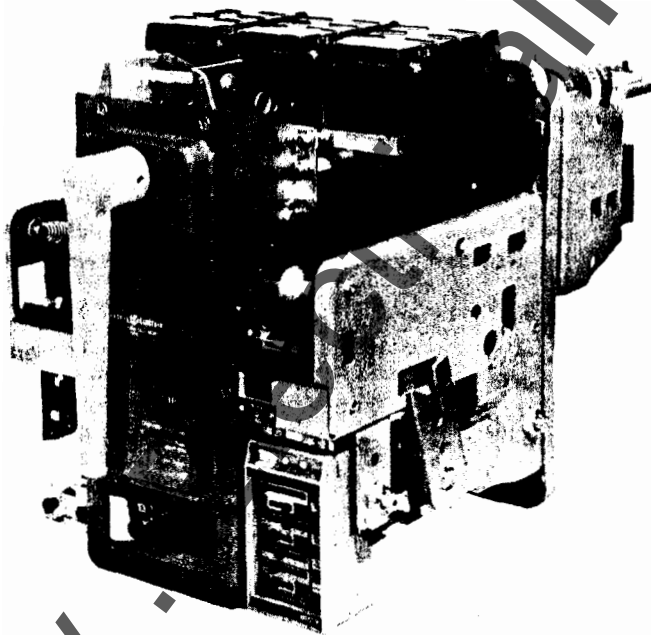

Fig. 2

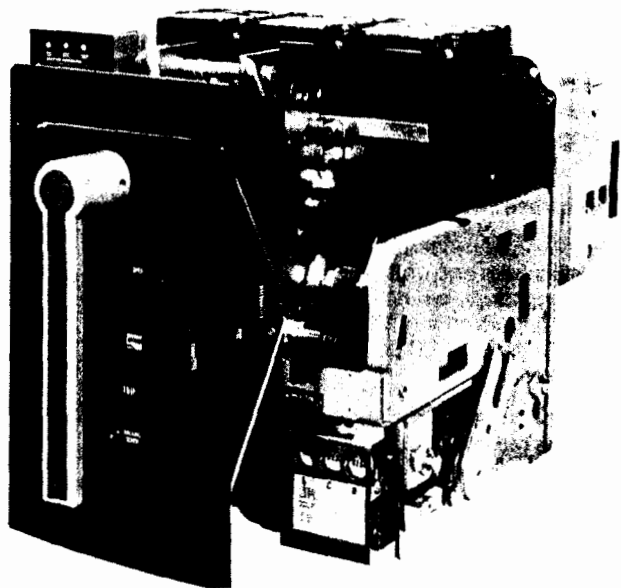

Fig. 3

2. AKD-6 switchgear breaker compartments are factory shipped less breakers and with the inner housing stowed in the CONNECTED position by a shipping bolt painted yellow. As the first step in preparing for breaker insertion, remove and discard this bolt and its shipping tag.

3. Pull the inner housing out until it stops. It will then be in the DISCONNECTED position.

4. Rotate the two track lock links and pull the right track all the way out.

5. Using a suitable lifting device, hoist the breaker until its mounting pins are approximately one inch above the tracks.

NOTE: To avoid damaging the arc quenchers, a spreader bar must be used for hoisting these breakers. Two hoisting slots are provided in each side frame—see Fig. 2. The spreader bar's hooks should be placed in the forward slots for non-fused breakers and in the rear slots for fused breakers.

6. Pull the left track out to the limit of its travel; lower the breaker onto the track so that its mounting pins drop into the track slots.

CAUTION: Breakers and tracks are equipped with rejection hardware which acts to prevent the tracks from accepting a breaker whose rating does not match that of the compartment. This rejection system is separately described under the heading INTER-CHANGEABILITY starting on Page 14.

7. Attach the racking handle to the racking screw thru the opening at the lower left corner of the breaker escutcheon. Access to the racking screw is obtained by depressing the TRIP button and sliding the racking screw cover to the right; releasing the TRIP button locks the cover open.

8. Rotate the racking handle counterclockwise (if possible) until it stops, then remove it. The purpose of this step is to position the slotted crank arms at the proper angle necessary to engage the fixed racking pins in the compartment.

9. Push the breaker in against the track stops. Rotate the two track lock links to lock the breaker in place. Close the door.

10. Again insert the racking handle (as in Step 7) and rotate it clockwise until it stops. A few turns before the stop is reached, turning torque will noticeably increase as the breaker's disconnect fingers engage the stationary studs. The breaker is now in the CONNECTED position and the position indicator will show CONN.

The complete racking cycle requires approximately 24 turns of the racking handle.

11. Remove the racking handle and depress the TRIP button to close the racking screw cover.

Breaker Removal (Code A)

1. Trip the breaker.

2. Insert the racking handle and rotate it counterclockwise until it stops. The indicator should read DISC.

Toward the end of the above racking movement, the breaker's "closing spring interlock" is activated; this automatically discharges the closing spring (if in a charged state) but does not close the breaker.

3. Remove the racking handle, open the compartment door.

4. Rotate the two track lock links and pull the breaker all the way out.

5. Attach the lifting device and raise the breaker until its mounting pins clear the track.

6. Push the tracks into the compartment, then lower the breaker to a flat surface; avoid protrusions that could damage the internal parts of the breaker.

NOTE: After a breaker is removed from its compartment, the inner house cannot be manually pushed all the way back into the compartment. The latches that rest on the drawout mechanism pins prevent this.

CODE B (AKR SUBSTRUCTURE) (Fig. 4)

The AKR substructure is a self-contained, open-type framework serving as the stationary receptacle for a drawout breaker. Featuring closed-door type drawout operation, it is designed for convenient mounting in individual breaker compartments of drawout switchgear equipments. It provides means for making the primary and secondary connections to the removable breaker element and is factory aligned.

All AKR B-type breakers for use in substructures are equipped with a "deep" escutcheon instead of the standard escutcheon employed on the A-type models. This configuration allows the breaker to be racked between the CONNECTED and DISCONNECTED positions with the door closed. The door is hung on the compartment (not on the slide rails) and does not move with the breaker as it does in the A-type AKD-6 models.

The racking mechanism is breaker-mounted and is identical to that of the Code A breaker; the same support method (pins engaging slots in slide rails) is also used. In operation, the substructure traverses the same four drawout positions as the A-types: CONNECTED—TEST—DISCONNECTED—WITHDRAWN. Breaker position is registered directly by markings on the left side of the escutcheon, these becoming visible as it emerges through the door cutout.

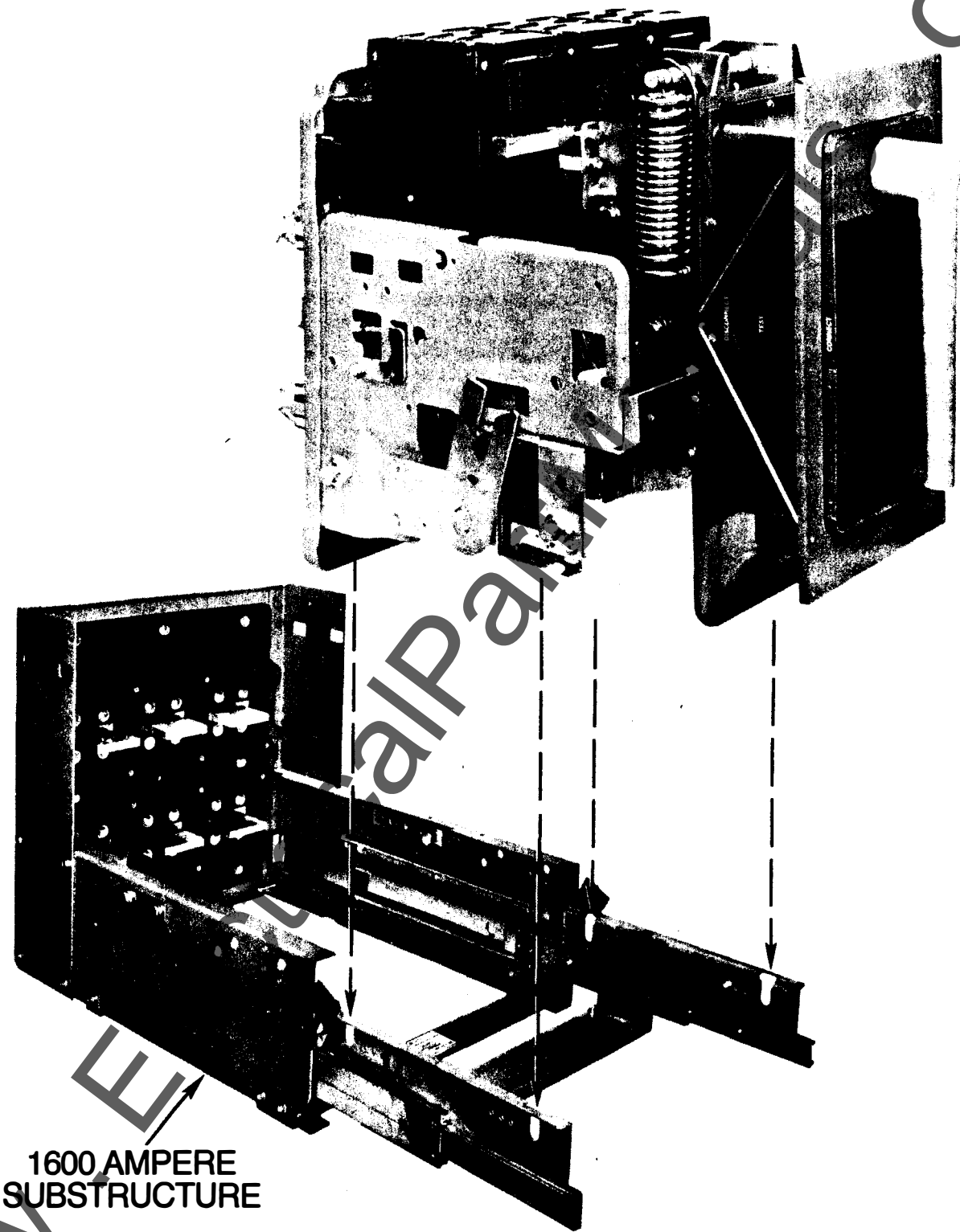

Figure 4. AKR-50 breaker, B-type drawout substructure mounting, manually operated

Breaker Insertion (Code B)

1. Prior to lifting a breaker to its intended compartment location, observe the following precautions:
 - a. *Check the compartment to insure that it is free of foreign objects.*
 - b. *Verify that the breaker is the correct type for that compartment.*
 - c. *Insure that the breaker is OPEN.*
 - d. *Apply a thin, fresh coat of D50HD38 lubricant to the breaker's primary disconnects.*
 - e. *Insure that the racking cams on the breaker are correctly positioned for initial engagement with the pins in the compartment. To do this, insert the racking handle and rotate it fully counterclockwise.*
2. Using a suitable lifting mechanism and spreader rig, raise the breaker above the elevation of the tracks. (Use the forward slots for non-fused breakers, the rear slots for fused models.)
3. Rotate the two track lock links and pull the tracks out to the limit of their travel.
4. Slowly lower and guide the breaker so that the breaker mounting pins drop into the slots in the tracks. Remove the lifting device.
5. Push the breaker into the compartment until it reaches the track stops. This is the DISCONNECT position. At this point the racking arms are positioned to engage the fixed racking pins in the compartment, ready to begin the racking motion.
6. Close the compartment door. Insert the racking handle into the racking screw opening in the breaker escutcheon. By clockwise rotation of the handle, move the breaker through the TEST position into the CONNECTED position; the latter is indicated when the jackscrew comes to a solid stop.

Breaker Removal (Code B)

1. With the door closed and latch, trip the breaker.
2. Insert the racking handle and rotate it counterclockwise until the breaker travels from CONNECTED through TEST to the DISCONNECTED position, as indicated by the jackscrew coming to a solid stop. This operation should be performed with the door closed. If the breaker closing spring is fully charged, it will be automatically discharged a few turns before the end of the racking action.
3. Open the compartment door. Rotate the two track lock links and pull the breaker out to the track travel limit—this is the WITHDRAWN position.
4. Before proceeding with subsequent operations to remove the breaker from the compartment, visually check the breaker's spring charge and close indicators to verify that breaker is open and the springs are discharged.
5. Attach the lifting device and hoist the breaker until its mounting pins clear the track slots.
6. Swing the breaker forward until the primary disconnects clear the compartment; lower the breaker onto a flat surface free of protrusions that could damage the breaker's internal parts.

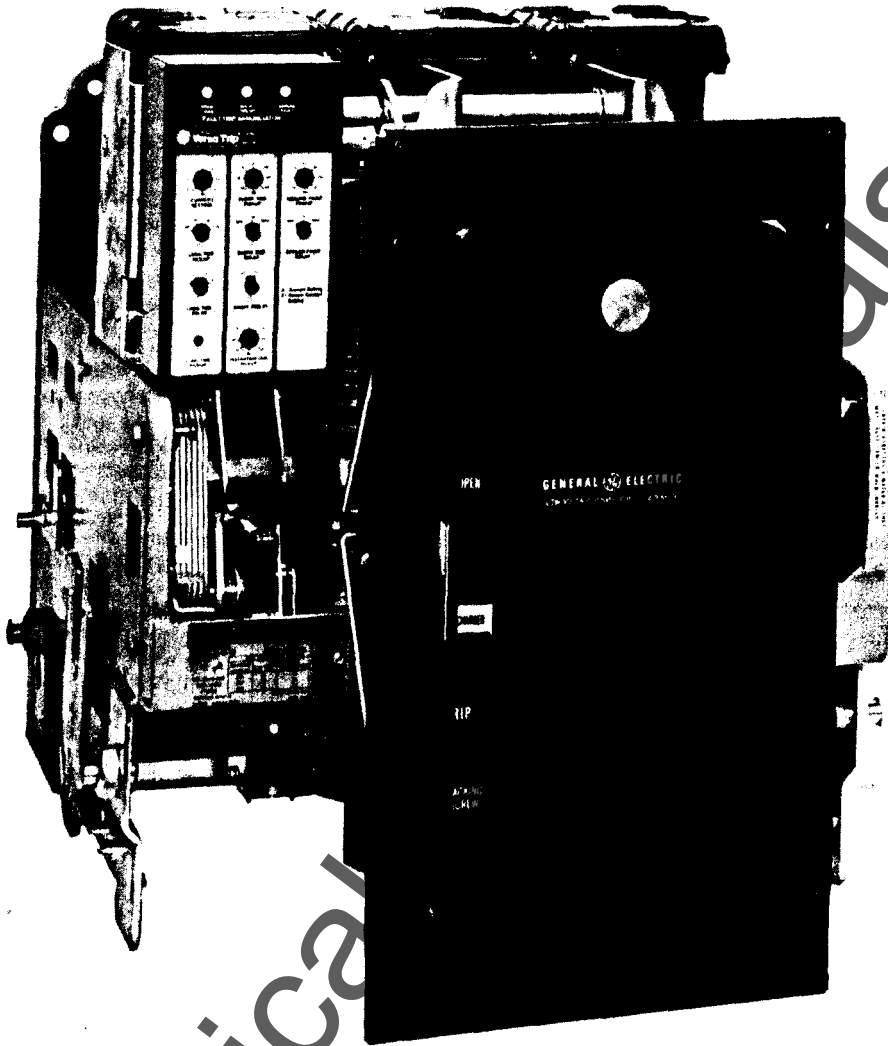

AKR-6D-50

Fig. 5

CODE D (AKD-8 SWITCHGEAR) (Fig. 5)

This type drawout breaker is supported by two protruding pins on each side of its frame; these engage slots in telescoping slide rails (tracks) mounted to each sidewall of the switchgear. Unlike AKD-6 Switchgear the door on AKD-8 switchgear remains stationary and closed while the breaker is racked out from the connected, thru test to disconnected position.

All AKR D-type breakers for use in AKD-8 are equipped with a deep escutcheon instead of the standard escutcheon employed on the A-type models.

The drawout operation features four discrete positions:

CONNECTED—This is the breaker's "In-Service" position. It is fully inserted in its compartment; the primary and secondary disconnect contacts are fully engaged. The breaker must be tripped before it can be racked into or out of this position.

TEST—In this position the primary contacts are disconnected but secondary contacts remain engaged. This allows complete breaker operation without energizing the primary circuit.

DISCONNECTED—Both primary and secondary contacts are disengaged.

WITHDRAWN—With the compartment door open, the breaker can be manually pulled out to the WITHDRAWN position. At this point the tracks are fully extended and the breaker is completely out of its compartment, ready for removal. Note that the racking mechanism is not employed for movement of the breaker between the DISCONNECTED and WITHDRAWN positions.

Breaker Insertion (Code D)

1. Prior to lifting a breaker to its intended compartment location, observe the following precautions:

- a. Check the compartment to insure that it is free of foreign objects.
- b. Verify that the breaker is the correct type for that compartment.
- c. Insure that the breaker is OPEN.
- d. Apply a thin, fresh coat of D50HD38 lubricant to the breaker's primary disconnects.
- e. Insure that the racking cams on the breaker are correctly positioned for initial engagement with the pins in the compartment. To do this, insert the racking handle and rotate it fully counterclockwise.

2. Using a suitable lifting mechanism and spreader rig, raise the breaker above the elevation of the tracks. (Use the forward slots for non-fused breakers, the rear slots for fused models.)

The in and out movement of the breaker between CONNECTED-TEST-DISCONNECTED positions is identical to "A" type AKD-6 models with the exception of breaker positioning indication. AKR-"D" type breaker position is registered directly by markings on the left and right side of the escutcheon, these becoming visible as it emerges through the door cutout.

3. Slowly lower and guide the breaker so that the breaker mounting pins drop into the slots in the tracks. Remove the lifting device.

4. Push the breaker into the compartment until it reaches the track stops. This is the DISCONNECT position. At this point the racking arms are positioned to engage the fixed racking pins in the compartment, ready to begin the racking motion.

5. Close the compartment door. Insert the racking handle into the racking screw opening in the breaker escutcheon. By clockwise rotation of the handle, move the breaker through the TEST position into the CONNECTED position; the latter is indicated when the jackscrew comes to a solid stop.

Breaker Removal (Code D)

1. With the door closed and latch, trip the breaker.

2. Insert the racking handle and rotate it counterclockwise until the breaker travels from CONNECTED through TEST to the DISCONNECTED position, as indicated by the jackscrew coming to a solid stop. This operation should be performed with the door closed. If the breaker closing spring is fully charged, it will be automatically discharged a few turns before the end of the racking action.

3. Open the compartment door. Pull the breaker out to the track travel limit—this is the WITHDRAWN position.

4. Before proceeding with subsequent operations to remove the breaker from the compartment, visually check the breaker's spring charge and close indicators to verify that breaker is open and the springs are discharged.

5. Attach the lifting device and hoist the breaker until its mounting pins clear the track slots.

6. Swing the breaker forward until the primary disconnects clear the compartment; lower the breaker onto a flat surface free of protrusions that could damage the breaker's internal parts.

CONNECTIONS

In all electrical connections good joint conductivity is a must. When making power connections to stationary breakers, the mating joint surfaces must be clean and have a smooth finish. They should be parallel and firmly bolted or clamped together. In addition, the bus or cable conductors must have ample ampacity to prevent overheating.

Control Connections

The outgoing connections to a breaker's accessories and control devices must be in accordance with the specific wiring diagram applicable to that breaker.

Control connections to stationary breakers are made to a terminal board mounted on the breaker. Figure 6 shows typical closing and tripping connections. If equipped with an overcurrent trip device which includes a ground fault element for use on 4-wire circuits, an additional terminal board is provided on the breaker for connecting to the equipment-mounted neutral sensor (physically located in the neutral conductor).

On drawout breakers the control circuits terminate in the breaker compartment on the stationary portion of separable secondary disconnects — see fig. 7.

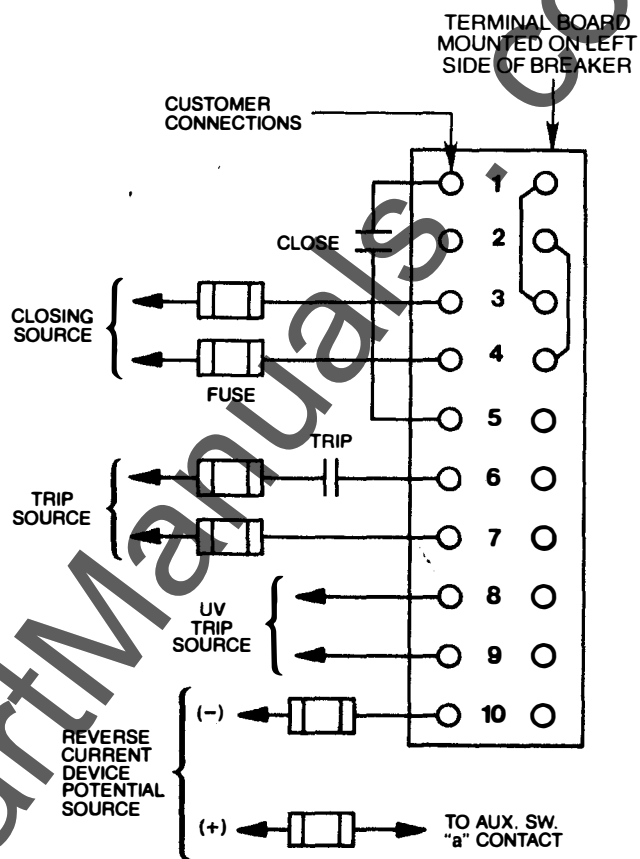

Fig. 6 Control connections to stationary breakers—front view.

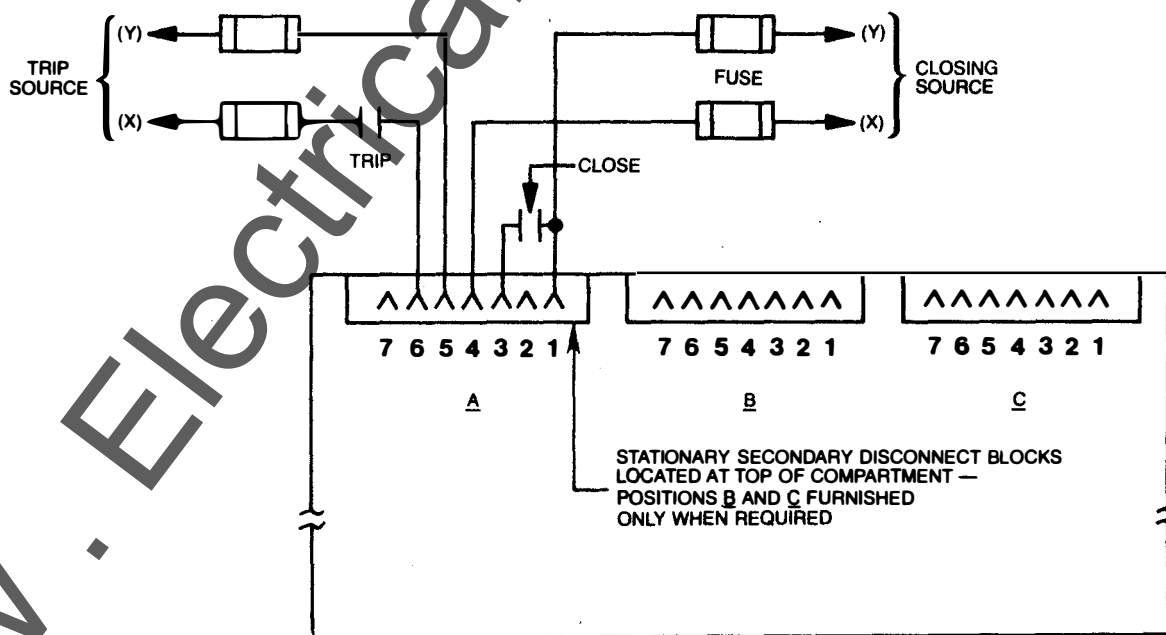

Fig. 7 Control connections to drawout breakers—front view of breaker compartment.

OPERATION

GENERAL

A breaker may be equipped to operate either manually or electrically. Both types of operation result in the same fast-closing movement as far as the contact action is concerned. The variation is in the way energy is stored in the closing spring, and how it is released.

MANUAL CLOSING

Manually operated AKR breakers are constructed with front-mounted handles. Handle operation resets the mechanism and fully charges the closing spring. A complete charge is accomplished in either cranking the handle through one cycle (135-degree swing) or three cycles (50-degree swing). The CLOSE button, mounted on the escutcheon, is used to close the breaker contacts and the TRIP button to open them.

If equipped with a closing solenoid, a manual breaker may be closed remotely by a control switch or relay. Before this can be done, however, the closing spring has to be charged by hand. The closing solenoid is an optional accessory and is not supplied unless specified in the breaker order.

ELECTRICAL CLOSING

On electrically operated breakers the closing springs are charged by a gear motor. With the springs discharged, voltage applied to the control circuit will energize the motor through the "G" switch contacts — see fig. 8. The motor, through the gear reduction output crank, compresses the closing springs until they are fully charged. As this fully charged position is reached, mechanically operated switches "F" and "G" reverse their shown position, the "G" switch deenergizing the motor and the "F" switch establishing a circuit to the "X" relay. At the same time, a mechanical prop is positioned to prevent the discharge of the fully charged closing spring.

With the closing spring propped fully-charged, the breaker is ready for closing. This may be accomplished electrically by depressing the closing switch on the breaker (if so equipped) or by a remote closing switch. Operation of the closing switch energizes the "X" relay, which in turn energizes the closing solenoid. This removes the prop, releasing the closing springs to close the breaker.

As the closing relay is energized, it energizes anti-pump relay "W". If the closing switch is maintained closed, the anti-pump relay will remain picked-up to prevent a second closing operation on the breaker in the event it is tripped open automatically. The closing impulse must be released and reapplied before a second closing operation can occur.

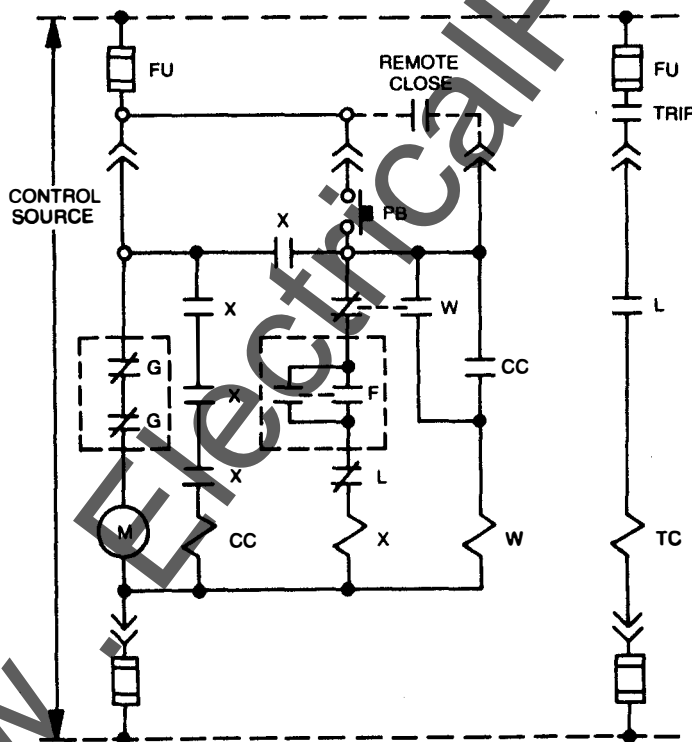

LEGEND

- CC** — CLOSING SOLENOID
- F** — CUTOFF SWITCH, CLOSED WHEN CLOSING SPRING IS FULLY CHARGED.
- G** — CUTOFF SWITCH, OPEN WHEN CLOSING SPRING IS FULLY CHARGED
- L** — AUXILIARY SWITCH
- M** — CHARGING MOTOR
- PB** — CLOSE PUSHBUTTON ON BREAKER ESCUTHEON, OPTIONAL.
- TC** — SHUNT TRIP DEVICE
- W** — ANTI-PUMP RELAY
- X** — CONTROL RELAY

Fig. 8 Elementary diagram for electrically operated drawout breaker.
Contact positions are shown with breaker open and closing springs discharged.

TRIPPING

In the closed position, the breaker's movable contacts are held in by a toggle linkage. The breaker is tripped open by displacing a mechanism latch which allows this toggle linkage to collapse. The trip latch is rigidly fastened to a horizontal trip shaft running from left to right through the breaker. In turn, the trip shaft carries paddles actuated by the manual trip button and the various other trip devices — overcurrent, reverse current, shunt trip, undervoltage, open fuse lockout. Viewing the breaker from the right, rotating the trip shaft counterclockwise

trips the breaker; clockwise movement resets the mechanism latch.

In addition to tripping the breaker, some devices hold the breaker trip free, i.e., prevent the contacts from closing even though a closing impulse is applied to the mechanism. Such devices are the undervoltage, bell alarm and lockout, electric lockout, open fuse lockout, and the key operated locks. These devices and the drawout mechanism interlocks must be in the reset position before the breaker can be closed.

FUSED BREAKERS

The AKRU-30/50 type breakers employ current limiting fused mounted integrally with the breaker (see Fig. 9). Included is an open fuse lockout device (OFLO) to prevent single-phasing in the event only one fuse blows.

The OFLO is a special trip device having three (3) shunt trip elements (one per phase), the coil of each being connected

across its corresponding fuse. The arc voltage generated by a blown fuse activates its OFLO shunt trip coil, thereby tripping the breaker and preventing single phase power from being supplied to the load. An indicator on the OFLO device signals which fuse is blown. The breaker cannot be closed until the blown fuse is acknowledged by resetting the OFLO. The fuse, of course, must be replaced.

MAINTENANCE

INSPECTION

Periodic inspection of the circuit breaker is recommended at least once a year. More frequent inspections are recommended where severe load conditions, dust, moisture or other unfavorable conditions exist, or if the vital nature of the load warrants it.

Always inspect the breaker after a short-circuit current has been interrupted.

At the time of inspection, the following checks should be made after the breaker has been deenergized:

1. Manually operate the breaker several times, checking for obstructions or excessive friction. Manual closing of an electrically operated breaker may be performed by the following two steps:

(1) Install maintenance crank (568B386G1) to the motor gear reducer shaft on the front right side of the breaker. Ratchet the maintenance crank up and down until the springs are fully charged as indicated by the distinct click as the prop is set and prevents any further charging of the closing springs. After the prop is set do not apply undue force to the maintenance handle.

(2) Manually pull the armature of the closing solenoid (located behind the lower right-hand corner of the escutcheon) toward the front of the breaker. This dislodges the prop and allows the closing springs to discharge, closing the breaker.

2. Electrically operate the breaker several times to check performance of the electrical accessories.

3. Visually check the breaker for loose hardware on the breaker and the bottom of the compartment for any hardware that has fallen from the breaker.

4. Remove the arc quenchers and inspect the arc quenchers and contacts for breakage or excessive burning.

5. The performance of the solid-state current trip devices may be checked with a suitable test set. Check electromechanical devices for positive trip in accordance with the instructions in their Maintenance Manual. (GEK-64459)

6. Check insulating parts for evidence of overheating and for cracks that indicate excessive thermal aging.

LUBRICATION

In general, the circuit breaker requires moderate lubrication. Bearing points and sliding surfaces should be lubricated at the regular inspection periods with a thin film of GE Lubricant D50HD38 (Mobil 28). Before lubricating, remove any hardened grease and dirt from latch and bearing surfaces with kerosene. ALL EXCESS LUBRICANT SHOULD BE REMOVED WITH A CLEAN CLOTH TO AVOID ACCUMULATION OF DIRT OR DUST.

On drawout breakers the contact surface of the disconnect studs should be cleaned and greased with GE Lubricant D50HD38. (Order part number 193A1751P1)

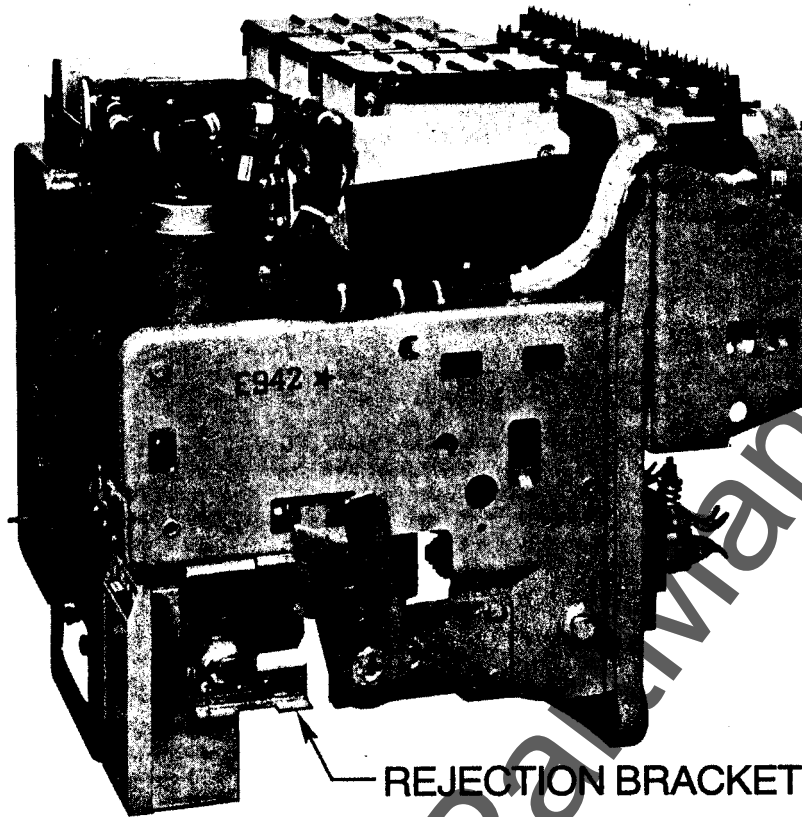

Figure 9. AKRU-5A-30 integrally fused breaker

INTERCHANGEABILITY OF DRAWOUT BREAKERS

In general, drawout breakers of the same type and rating are interchangeable in their equipment compartments. Drawout breakers of different frame sizes or short circuit ratings are intentionally made non-interchangeable. To prevent inserting the wrong type breaker into a drawout compartment, unique "rejection hardware" is affixed to each breaker and its compartment. Figure 9 shows a typical breaker-mounted rejection bracket which aligns with a rejection pin in the drawout rail (Fig. 10). When the wrong type breaker is inserted into a compartment, the bracket and pin do not mate, preventing the breaker from seating itself into the rail slots.

There is one exception to the above. Breakers of the same frame size having different short circuit ratings may be interchanged in one direction only. Specifically,

- a. An AKR-30H can be inserted into an AKR-30 compartment.
- b. An AKR-50H can be inserted into an AKR-50 compartment.

The rejection hardware prevents the converse of a. and b.

Figures 15, 16 and 17 display the rejection pin/bracket combinations employed for the various breaker models and frame sizes. As dictated by its intended breaker type, each drawout compartment has its rejection pin(s) installed in posi-

tions A, B or C (Fig. 10 and 14) along the drawout rails. The AKRU-30 and -50 fused breakers employ a single bracket, while all non-fused breakers carry two brackets.

Note that the rejection hardware is identical for both A and B-type breakers; however, because their escutcheons are different, the breakers are not interchangeable. D type breaker rejection hardware is different than A or B type (Fig. 12 and 13)

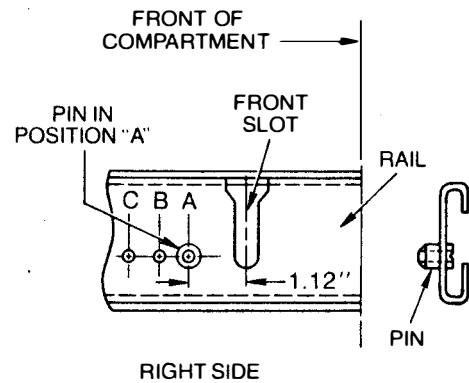

Fig. 10 Slide rail rejection pin locations (A-type rail shown)

Drawout breakers of the D type are interchangeable within KD-8 switchgear only. Drawout breakers of different frame size, short circuit ratings, horizontal or vertical lower studs are intentionally made non-interchangeable. To prevent inserting the wrong type breaker into a drawout compartment, unique rejection hardware is affixed to each breaker and its compartment. Fig 11 shows a typical breaker-mounted rejection bracket which aligns with a rejection pin in the drawout rail. When the wrong type breaker is inserted into compartment, the bracket and pin do not mate, preventing the breaker from sliding into the rail slot.

Breakers of the same frame size having different short circuit ratings may be interchangeable in one direction only. Fig 17 will show the interchangeable.

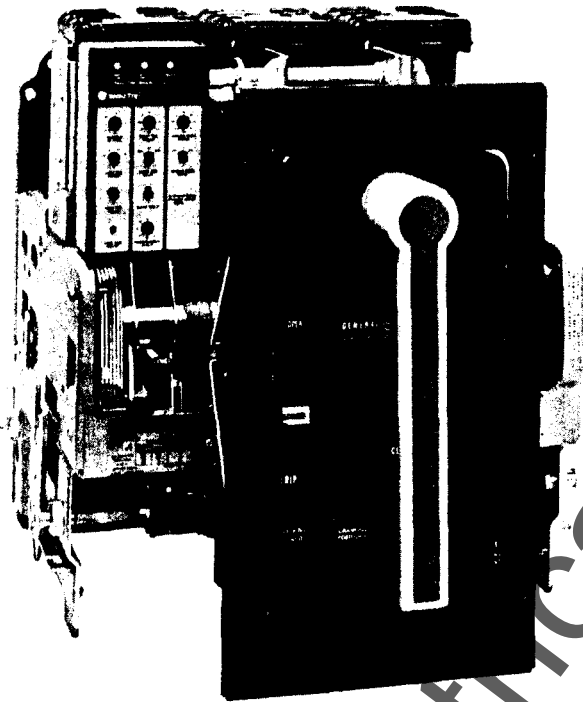

Fig. 11 ACR-6D-30

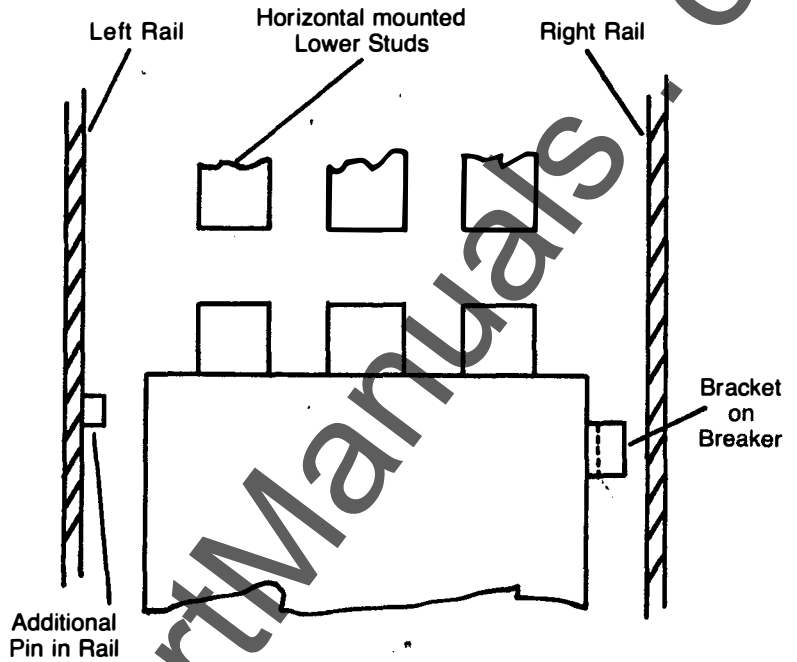

Fig. 12

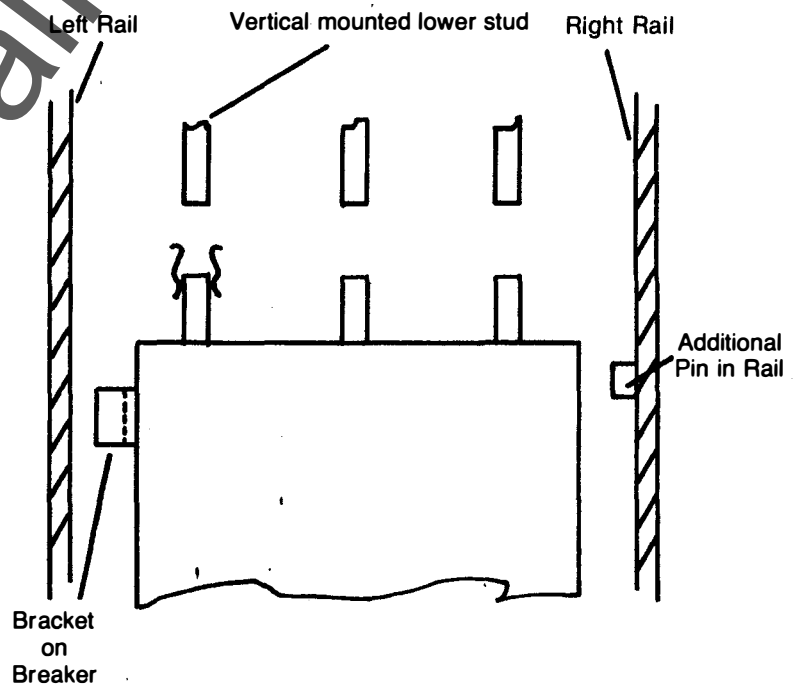

Fig. 13

"E-TYPE" REJECTION

Some installations require that breakers serving essential circuits be segregated from identical models deployed elsewhere in the power system. The segregation is physical and is accomplished by supplemental rejection hardware added to the breaker and its drawout compartment.

In this publication these special category breakers are designated as "E-type". They are interchangeable as follows:

- E-type compartments reject standard breakers.
- Standard compartments accept E-type breakers.

E-type rejection is an optional feature available on both A and B-type breakers. It is achieved by installing an extra pin in the right-hand slide rail which engages an additional notch in the breaker's rejection bracket—see Fig. 14.

All E-type breakers have the suffix letter E added to the middle digits of their designation as in the following example: AKR-4BE-30.

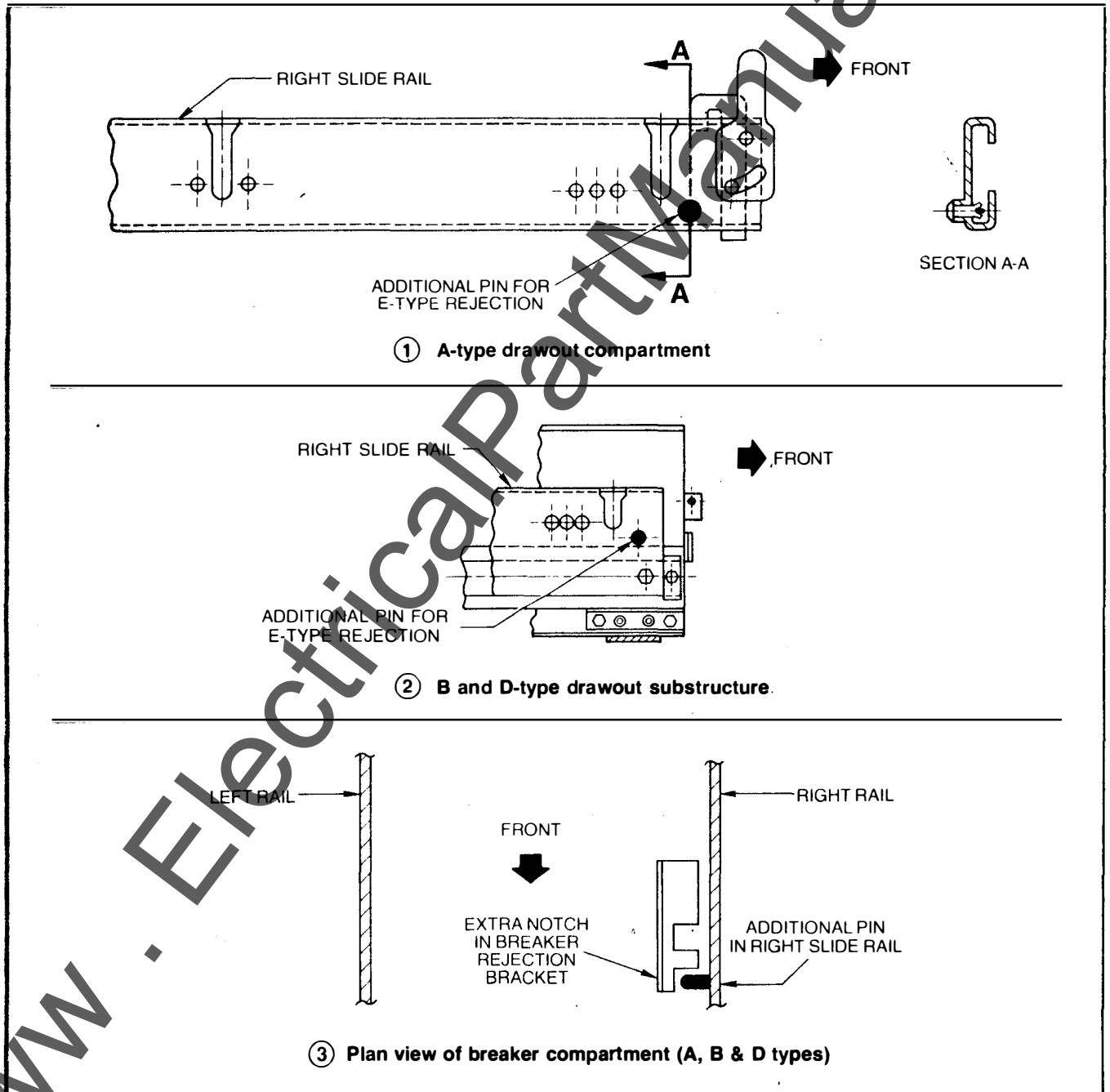
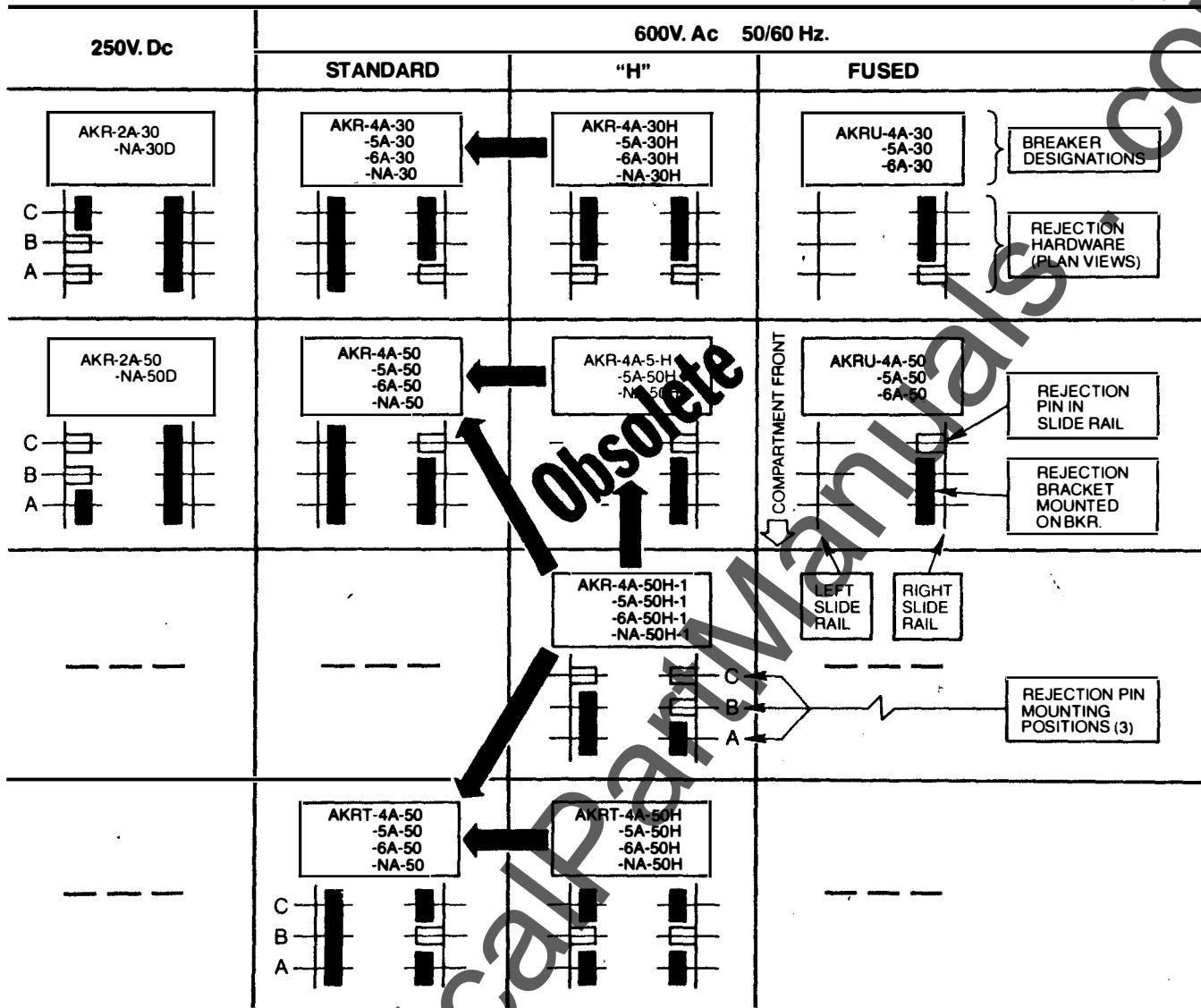
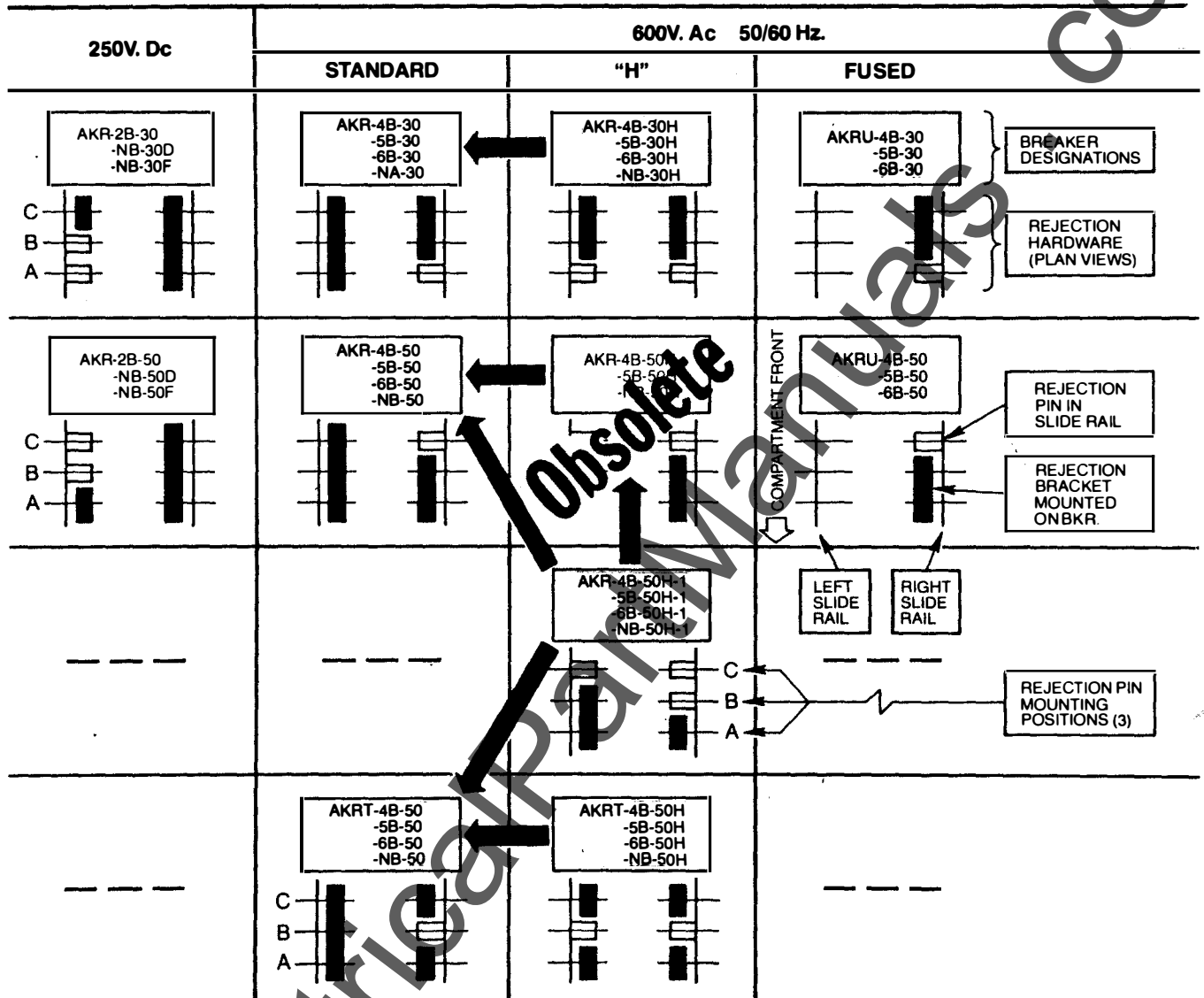

Figure 14. "E-type" rejection feature for drawout breakers (optional)



- NOTES:** (1) All breaker models listed within a given block are interchangeable.
- (2) Except where joined by arrows, units in one block are not interchangeable with units in any other block.
- (3) ← Denotes one-way interchangeability in direction indicated.

FIG. 15 – Interchangeability and rejection hardware chart for A-type drawout breakers used in AKD-6 switchgear.



- NOTES:** (1) All breaker models listed within a given block are interchangeable.
- (2) Except where joined by arrows, units in one block are not interchangeable with units in any other block.
- (3) ← Denotes one-way interchangeability in direction indicated.
- (4) These pin and bracket combinations are identical to those employed on the A-type breakers of fig. 15.

FIG. 16—Interchangeability and rejection hardware chart for B-type drawout breakers used in substructures.

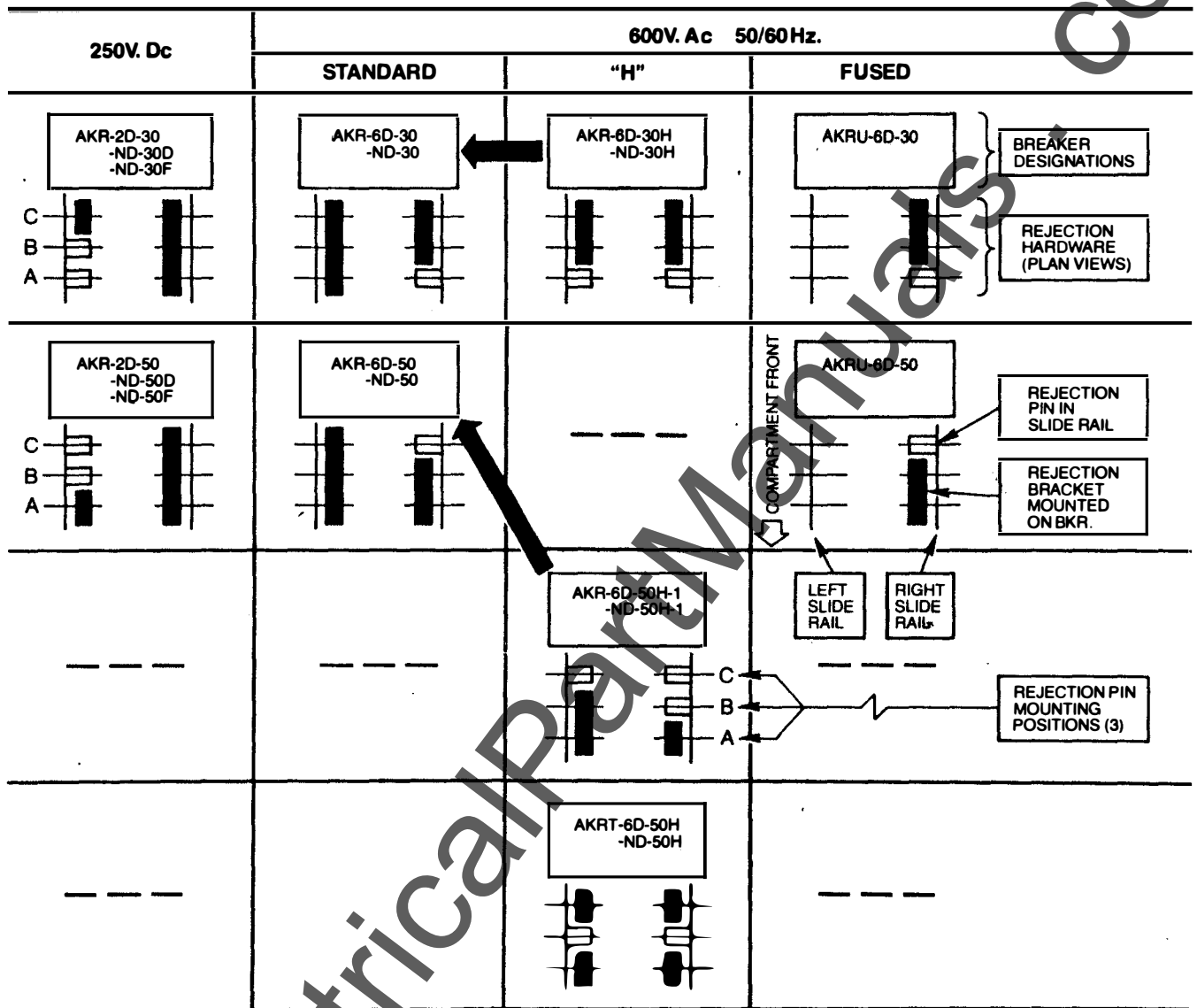

- NOTES:** (1) All breaker models listed within a given block are interchangeable.
- (2) Except where joined by arrows, units in one block are not interchangeable with units in any other block.
- (3) Denotes one-way interchangeability in direction indicated, providing lower studs are the same.
- (4) These pin and bracket combinations are identical to those employed on the A-type breakers of fig. 15.

FIG. 17—Interchangeability and rejection hardware chart for D-type drawout breakers used in AKD-8 switchgear.

TABLE 3. CURRENT RATINGS FOR AUXILIARY DEVICES

Voltage		Interrupting Rating (Amperes)			
		Auxiliary Switch		Bell Alarm Switch	EC-1 Switchette
Nominal	Range	Resistance Load	Electro-Magnet Load	Resistance or Electro-Magnet Load	
48 dc	38-56	25	15	—	—
125 dc	100-140	11	6.25	2.5	0.3
250 dc	200-280	2	1.75	0.9	0.15
600 dc	508-672	0.45	0.35	0.3	—
		75-85% Lagging PF	30-35% Lagging PF	75-85% or 30-35% Lagging PF	
120 ac	104-127	75	50	30	—
240 ac	208-254	50	25	15	10
480 ac	416-508	25	12	7	10
600 ac	520-635	12	8	5	—

Current Ratings	Amperes		
	Auxiliary Switch	Bell Alarm Switch	EC-1 Switchette
Continuous	20*	10*	10*
Closing (30-35% PF or Resistive)	50	30	**

*On drawout breakers, limited to 5 amperes continuous, based on rating of #16 control wire.

**Adequate for breaker shunt trip coils with voltage ratings same as tabulated above (12.3A max. for the 120V. ac coil).

These instructions do not purport to cover all details or variations in equipment nor to provide for every possible contingency to be met in connection with installation operation or maintenance. Should further information be desired or should particular problems arise which are not covered sufficiently for the purchaser's purposes, the matter should be referred to the General Electric Company.

For further information call or write your local General Electric Sales Office or . . .

Distribution Equipment Division
41 Woodford Avenue
Plainville, CT 06062

Outside the U.S. write Construction Equipment Export Operation
411 Theodore Fremd Ave., Rye, NY 10580

