



## BE1-851 OVERCURRENT PROTECTION SYSTEM

The BE1-851 is a multifunction, numeric relay that provides three phase, ground, and negative sequence overcurrent protection with four shot recloser, breaker failure, breaker monitoring, control, and metering functions in an integrated system.

### ADVANTAGES

- Allows the user to select the optimal response characteristic separately for phase and ground elements. Choose between fundamental, RMS, or average sensing algorithms.
- BESTlogic provides the user with complete flexibility in configuring a protection and control system. User programmable variable and switch names make these relays completely self documenting.
- Programmable LCD display allows the relay to replace local indication and control functions, such as panel metering, alarm annunciation, and control switches.
- Three independent communication ports with protocol support allows integration with distributed control systems.
- Real Time Clock with 8 hour capacitor ride through and optional battery backup.
- Available in three case configurations to provide cost saving in any installation. All three are fully drawout and fit cutout, drilling and behind panel projection dimensions for common Basler Electric, GE, and Westinghouse overcurrent relays. One includes test paddle for testing in case.

### WINDOWS® SOFTWARE

Interface for setting and communicating with Basler protection products  
Request BESTCOMS for BE1-851 (includes "settings compare" feature)

### ADDITIONAL INFORMATION

#### INSTRUCTION MANUAL

Request publication 9289900990

#### MODBUS™ INSTRUCTION MANUAL

Request publication 9289900992

#### DNP 3.0 INSTRUCTION MANUAL

Request publication 9289900995

**FEATURES**  
Pages 2 and 3

**APPLICATIONS**  
Page 3

**FUNCTIONAL  
DESCRIPTION**  
Pages 4-7

**BESTlogic**  
Pages 8 and 9

**SPECIFICATIONS**  
Pages 10 and 11

**ORDERING  
INFORMATION**  
Page 12



## FEATURES

### PROTECTION

- Sensing Input Type G
  - Phase and Neutral Instantaneous Overcurrent elements with settable time delay: 50TP, 150TP, 50TN, 150TN, 250TN, 350TN
  - Phase and Neutral Time Overcurrent elements: 51P, 51N, 151N
- Sensing Input Type H
  - Phase, Neutral, and Negative Sequence Instantaneous Overcurrent elements with settable time delay: 50TP, 150TP, 50TN, 150TN, 50TQ, 150TQ
  - Phase, Neutral, and Negative Sequence Time Overcurrent elements: 51P, 51N, 51Q
- All U.S. and IEC timing curves plus user programmable curve
- Responds to either Average AC, Fundamental, or Wide band RMS to 7th harmonic
- Minimizes transient overreach and overtravel on overcurrent elements
- Separate ground current input
- Breaker Failure protection function: BF
- Four general purpose logic timers: 62, 162, 262\*, 362\*
- Programmable Logic using BESTlogic
- Four protection setting groups with external or automatic (cold load pickup, load, unbalance, recloser shot) selection modes

\* Available when style option 1 is V or W.

### CONTROL

- Four shot recloser with zone sequence coordination and sequence controlled protective element blocking functions
- Virtual breaker control switch—controllable from both HMI and com. ports: 101
- Four virtual selector switches—controllable from both HMI and com. ports: 43, 143, 243\*, 343\*

\* Not available when style option 1 is V or W.

### INSTRUMENTATION

- Real time A, B, C phase, neutral, and negative sequence currents
- 1% meter accuracy down to 10% of nominal current

### REPORTS

- Current demands for phase, neutral, and negative sequence currents—magnitudes and time stamps are recorded for today's peak, yesterday's peak, and peak since reset
- Breaker operations counter and contact interruption duty

### FAULT RECORDING

- 255 event sequence of events report with I/O and alarm sub-reports
- Fault Reporting; 1 or 2 oscillography records per fault report

bcswitchgear.com | 888.599.0486

- Fault summary reports; two most recent Fault Summary Records saved to non-volatile memory
- 16 fault records, 15 cycles long @ 24 samples/cycle
- COMTRADE format

### COMMUNICATION PORTS

- Three independent general purpose communication ports
  - Front RS-232 ASCII communications
  - Rear RS-232 ASCII communications
  - Rear RS-485 ASCII, Modbus™, DNP or other common protocols
- IRIG-B time sync (unmodulated)

### SELF TEST AND ALARM FUNCTIONS

- Relay fail, major alarm, and minor alarm LEDs, and fail-safe alarm output contact (closed or open) See style chart, page 12, for ordering information.
- Extensive internal diagnostics monitor all internal functions of the relay
- More than 20 additional alarm points—programmable for major or minor priority Including:
  - Reclose fail and lockout
  - Phase demand overload alarm
  - Neutral and negative sequence unbalance demand alarms
  - Three breaker alarm points—programmable for slow trip, interruption duty threshold, or operations counter
  - Trip circuit voltage and continuity monitor
  - Close circuit monitor via BESTlogic

### PROGRAMMABLE I/O

- Four programmable inputs
- Five programmable outputs and one dedicated programmable alarm output

### HARDWARE FEATURES

- Three configurations, all full drawout
  - S1:Basler/GE style (testable in case)
  - H1:Half-rack
  - F1:Westinghouse FT11 size
- Active CT technology for low burden and increased dynamic range
- Flash Memory for upgrading embedded programming without changing chips
- Real Time Clock with 8 hour capacitor ride through and optional battery backup
- Integral HMI with 2x16 character display
- Wide range ac/dc power supply options provide long hold up time to ride through dips on ac power source. (100 ms with 4 output relays energized, upon complete loss of source. Starting voltage 125Vac for Option 1 (48/125Vac/dc) and 250Vac for Option 2 (125/250Vac/dc))

Need Help? 888.599.0486

## FEATURES, continued

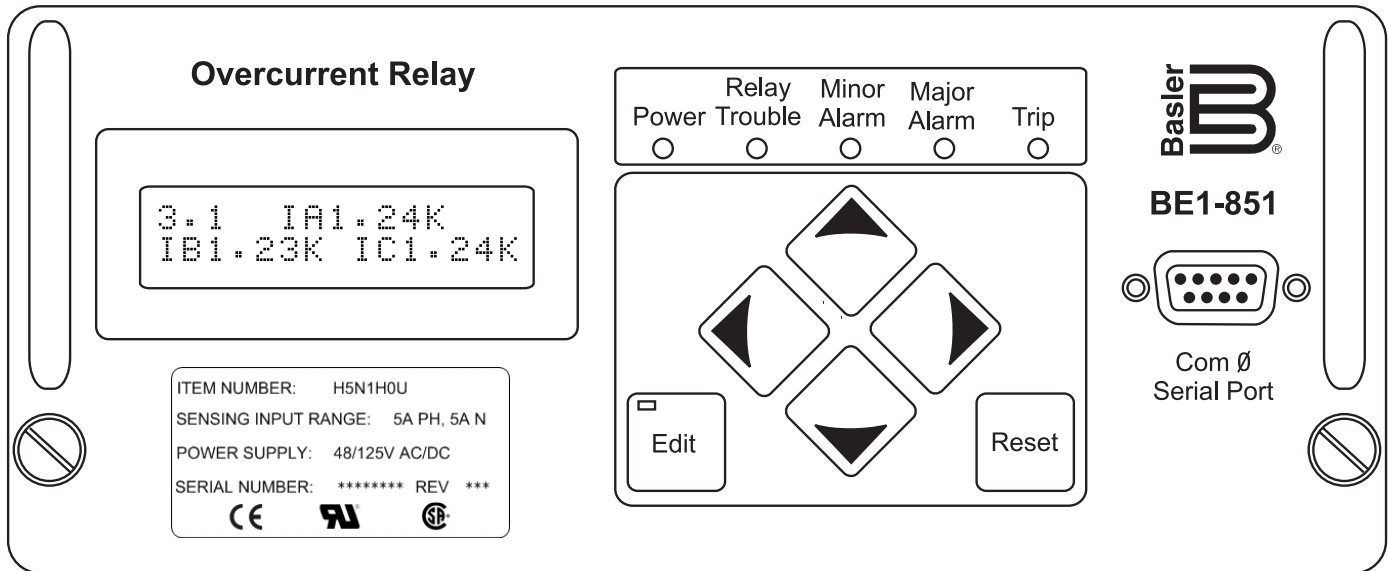

P0037-46  
05-19-06

**Figure 1 - Advanced HMI (Human Machine Interface)  
H1 Half Rack Front panel shown**

## APPLICATIONS

The BE1-851 Overcurrent Protection System provides three phase, ground, and negative sequence overcurrent protection and is intended for use in any non-directional overcurrent protection application. Its unique capabilities make it ideally suited for applications with the following requirements:

- Applications that require low burden to extend the linear range of CTs.
- Applications that require the flexibility provided by wide setting ranges, multiple setting groups, and multiple coordination curves in one unit.
- Applications that require the economy and space savings provided by a multifunction, multiphase unit. This one unit can provide all of the protection, as well as local and remote indication, metering, and control functions required on a typical circuit.
- Applications that require communication capability.
- Applications that require specific current response characteristics.
  - The fundamental digital signal processing (DSP) algorithm provides rejection of harmonics and low transient overreach.
  - The RMS DSP algorithm provides true wide band RMS measurement.
  - The average DSP algorithm provides a flat response characteristic over a wide frequency range.
- Applications where the optional case configurations facilitate modernizing protection and control systems in existing substations. One electromechanical overcurrent or reclosing relay can be replaced by a BE1-851 relay. The remaining relays can be removed or left in service as backup.
- Applications where the capabilities of a digital multifunction relay are required, yet test paddles and/or drawout construction are also required.
- Applications where bus protection is provided by a high speed bus overcurrent blocking scheme instead of a dedicated bus differential circuit.
- Applications where the capabilities of intelligent electronic devices (IEDs) are used to decrease relay and breaker maintenance costs.

## FUNCTIONAL DESCRIPTION

The BE1-851 is a multifunction, numeric relay that provides a comprehensive mix of protective, control and metering functions in an integrated system. This system is suitable for any nondirectional overcurrent application including feeder applications, generator applications, cogeneration applications, and transformer backup.

The BE1-851 has the unique ability to provide specific current response characteristics. It does this in three different ways:

- The Fundamental twenty-four sample per cycle Digital Signal Processing (DSP) algorithm provides rejection of harmonics and low transient overreach.
- The RMS DSP algorithm provides true wide band RMS measurement.
- The Average DSP algorithm provides a flat response characteristic over a wide frequency range.

These characteristics are independently settable for phase and neutral quantities.

The unit has one set of three phase and neutral current sensing inputs to provide all common protective functions for substation and feeder applications. Selection of sensing input Type G offers additional application flexibility by providing the Protection Engineer with three additional ground currents in lieu of the negative sequence function.

The half rack case is fully drawout with current circuit shorting provisions. Two Basler Electric half rack IEDs (Intelligent Electronic Devices) such as primary and backup BE1-851 or the BE1-951 or BE1-GPS100 can be dovetailed together to mount in a standard 19" equipment rack with no special mounting hardware.

The S1 and F1 cases allow savings in modernizing existing facilities. One overcurrent or reclosing relay can be removed from the panel and replaced with a state-of-the-art communicating multifunction relay. Remaining relays can be removed or left in place for backup. Available adapter plates broaden the types of relays that can be readily replaced with no panel cutting.

Three independent communications ports, along with built-in support for Modbus™ and other common protocols, provide easy access to integrating the protection, control, metering, and status monitoring

functions into a substation automation system. The standard IRIG-B port provides time synchronization from a master clock.

Real time metering provides amp and unbalance loading telemetry for the protected circuit. Contact sensing inputs and alarm monitoring functions provide real time status information. Remote control is provided by virtual control and selector switches with select-before-operate control of programmable outputs.

### **BESTlogic**

BESTlogic programmable logic provides the user with high flexibility in configuring a protection and control system.

Each of the protection and control functions in the BE1-851 is implemented as an independent function block that is equivalent to its single function, discrete device counterpart. Each independent function block has all the inputs and outputs that the discrete component counterpart might have. Figures 6A and 6B show each of the independent function blocks available for use in the BE1-851. Programming BESTlogic is equivalent to choosing the devices required by your protection and control scheme and drawing schematic diagrams to connect the inputs and outputs to obtain the desired operational logic.

The BE1-851 relay can store, as user settings, one user programmable, custom logic scheme. To save you time, several preprogrammed logic schemes have also been provided. Any of the preprogrammed schemes may be copied into the logic settings without making any additional BESTlogic settings.

BESTlogic provides the protection engineer with the flexibility to set up this powerful multifunction system with the same freedom that was once enjoyed with single function, discrete devices. It is no longer necessary to compromise your standard protection and operating practices to deal with the limitations in programmability of previous multifunction devices.

Figures 2A, 2B, 2C, and 3 show typical external connections, and Figures 5A, 5B and 5C show rear panel connections.

## FUNCTIONAL DESCRIPTION, continued

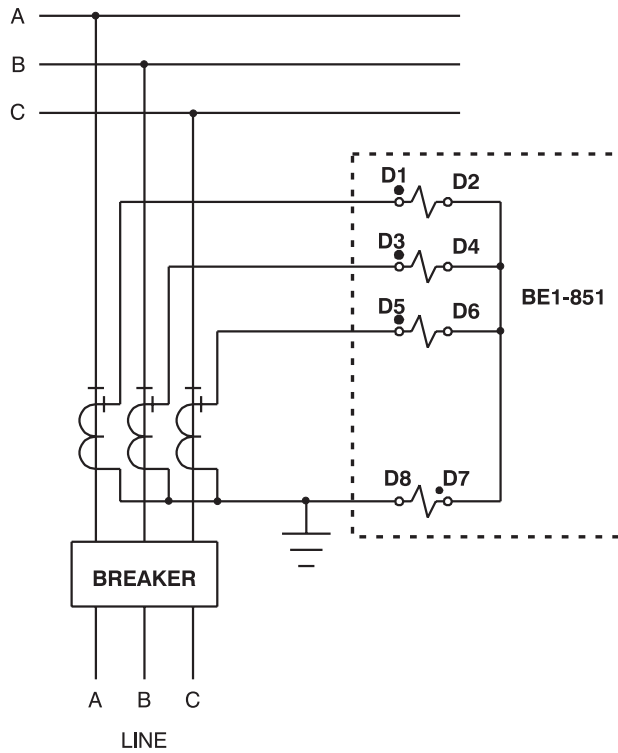

Figure 2A - Typical External Sensing Connections - Feeder Breaker Application

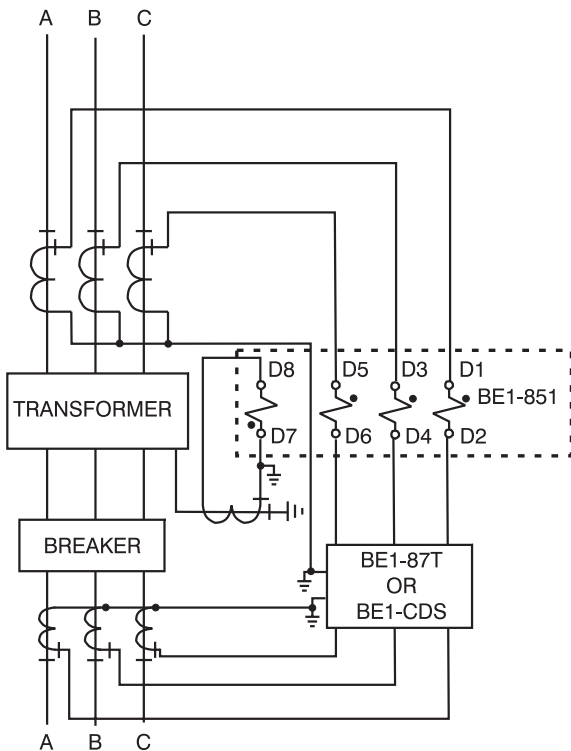

Figure 2B - Typical External Sensing Connections - Transformer Backup Application

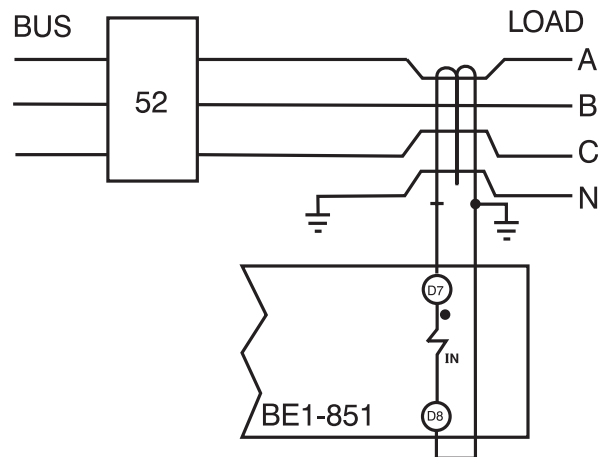
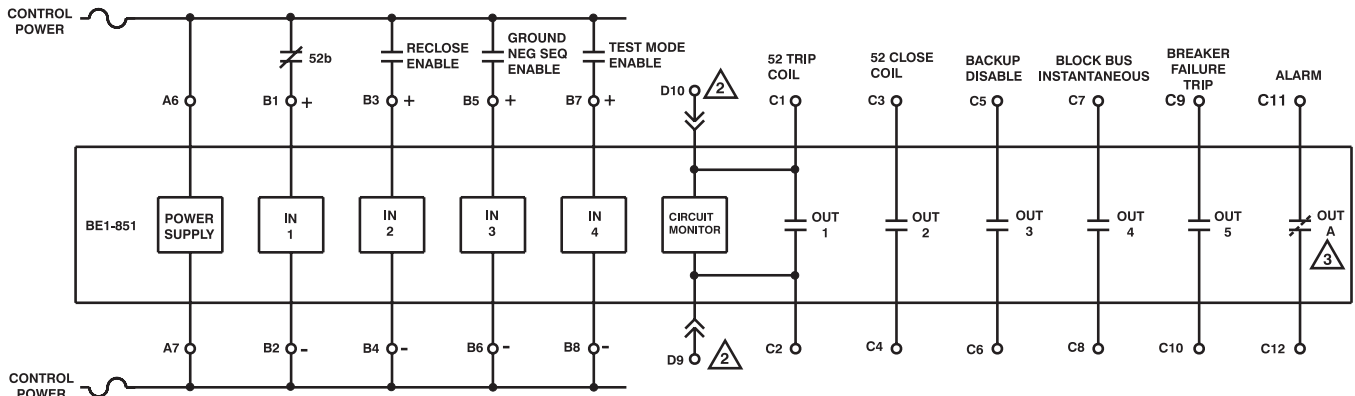

Figure 2C - Alternate Connections for  $I_N$

## FUNCTIONAL DESCRIPTION, continued



- NOTES:
- 1.) CONNECTIONS SHOWN ARE FOR USE WITH PRE-PROGRAMMED LOGIC SCHEME FEEDER\_3. ALL INPUTS AND OUTPUTS ARE FULLY PROGRAMMABLE USING BESTLogic.
  - 2. ADDITIONAL OUTPUT 1 TERMINAL CONNECTIONS D9 & D10 WITH TEST PLUG ARE AVAILABLE IN S1 CASE VERSION ONLY.
  - 3. THE FAIL-SAFE ALARM OUTPUT CAN BE NORMALLY-CLOSED (NC) OR NORMALLY-OPEN (NO). VERIFY CONFIGURATION BY REFERRING TO THE STYLE CHART.

Figure 3 - Typical External Connections

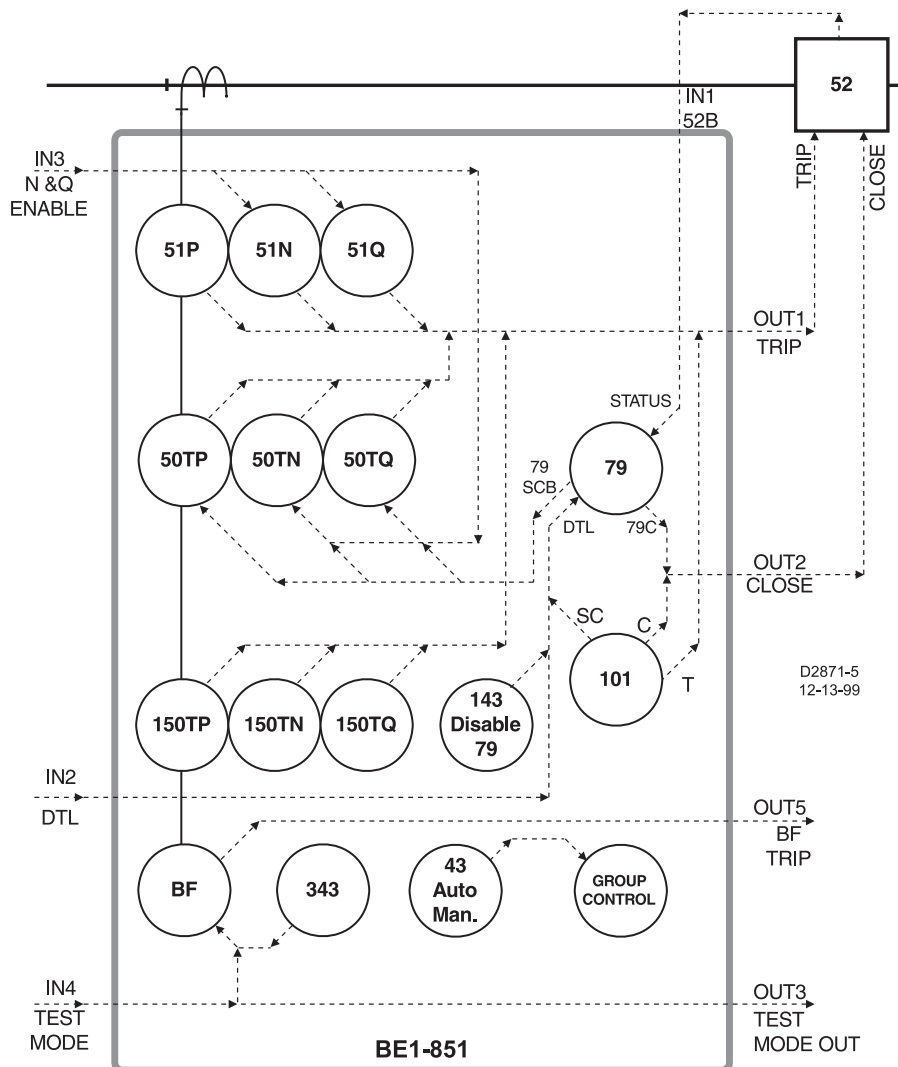

Based upon pre-programmed logic FEEDER\_3.  
 Not all available protection and control functions are shown.

Figure 4 - Typical Application Single Line

## FUNCTIONAL DESCRIPTION, continued

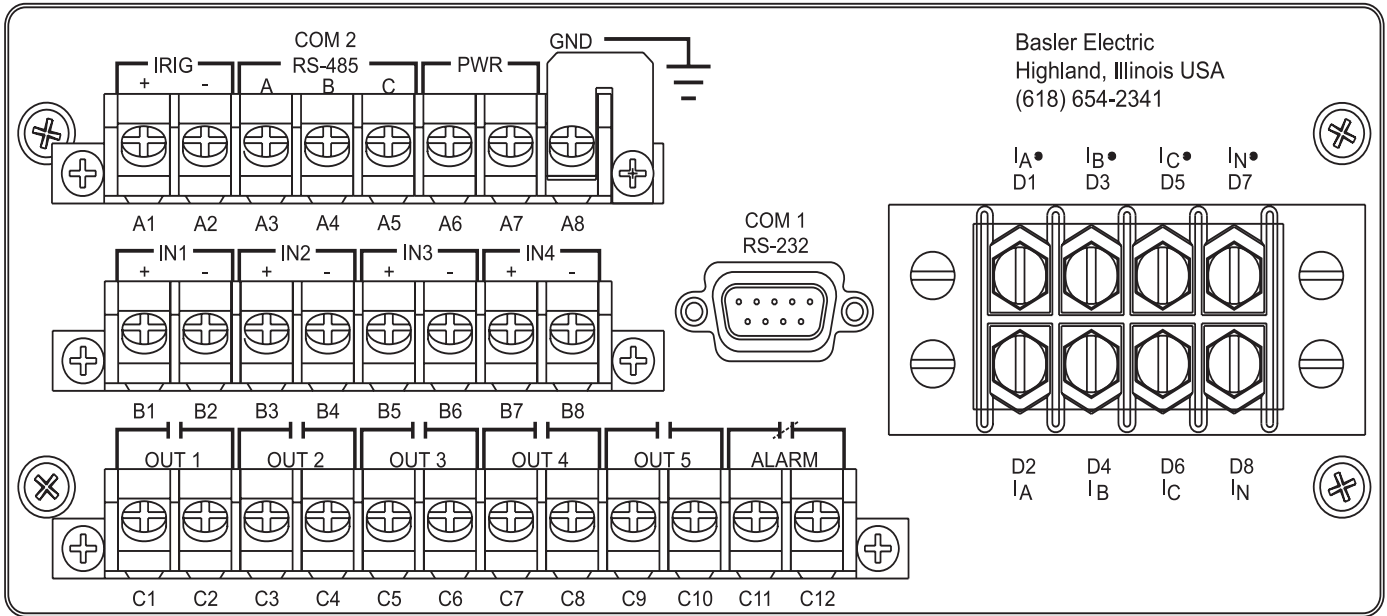

Figure 5A - BE1-851 H1 Rear Panel Connections

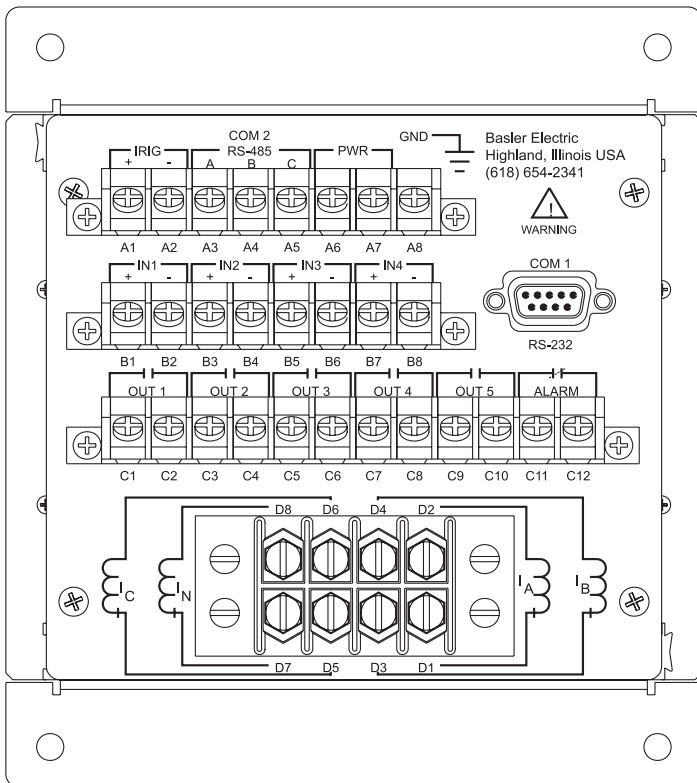

Figure 5B - BE1-851 F1 Rear Panel Connections

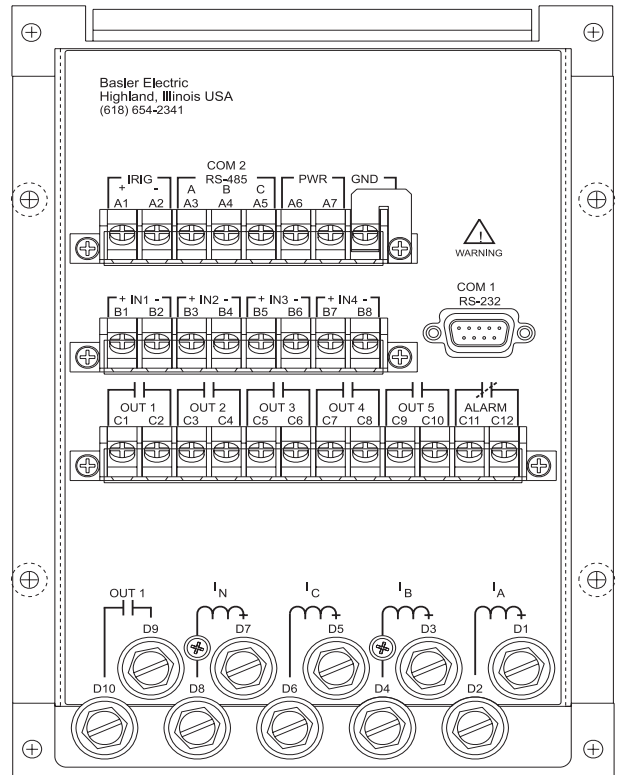

Figure 5C - BE1-851 S1 Rear Panel Connections

**Note:** Depending upon the style number of the relay, the Alarm output contacts may be normally-closed (NC) or normally-open (NO). Verify the Alarm contact configuration by referring to the style chart.



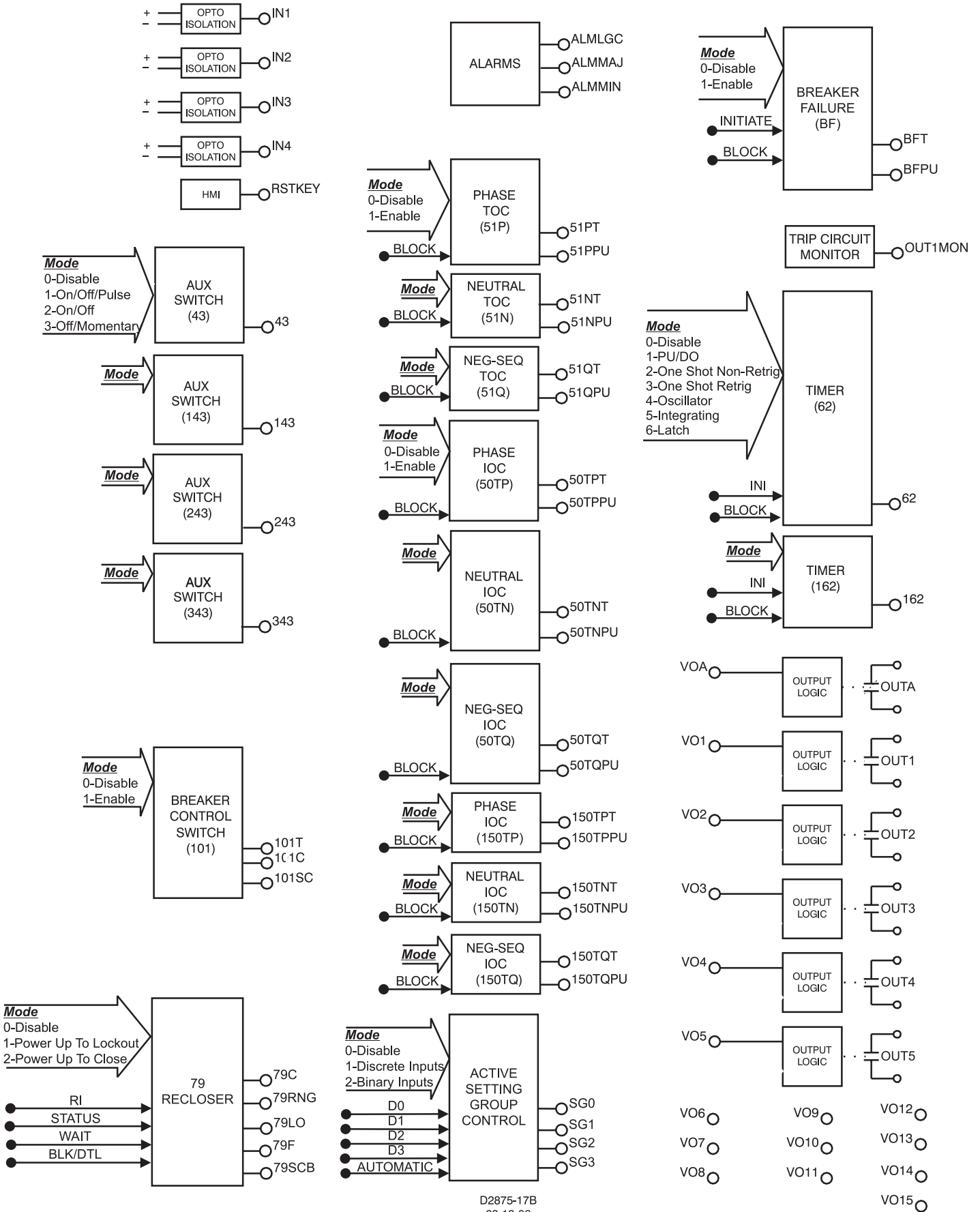

Figure 6B - BESTlogic Sensing Input Type H Function Blocks

## GENERAL SPECIFICATIONS

### 5 Amp CURRENT INPUTS

Continuous:	20 Amps
One Sec. Rating:	400 Amps
Saturation limit:	150 Amps
Max. Burden:	<10 milliohms

### 1 Amp CURRENT INPUTS

Continuous:	4 Amps
One Sec. rating:	250 Amps
Saturation limit:	30 Amps
Max. Burden:	<22 milliohms

### A/D CONVERTERS

Sampling Rate:	24/cycle
----------------	----------

### POWER SUPPLY

Option 1:	DC Range 35-150V AC Range 55-135V
Option 2:	DC Range 90-300V AC Range 90-270V
Option 3:	DC Range 17-32V (down to 8V for momentary dips)
Burden:	6 W continuous, 8 W maximum with all outputs energized

### OUTPUT CONTACTS

Make and carry:	30A (0.2sec)
Continuous:	7A
Break:	0.3A DC (L/R=0.04) @ 125Vdc or 250Vdc

### CONTROL INPUTS

Wetting Voltage range: Same as control power supply option.

Power Supply Option	Low Range		High Range	
	Turn-on Voltage Range	Burden	Turn-on Voltage Range	Burden
1) 48/125Vac/Vdc	26-38V	13k ohms	69-100V	24k ohms
2) 125/250Vac/Vdc	69-100V	25k ohms	138-200V	54k ohms
3) 24Vdc	5-8Vdc	7k ohms	N/A	N/A

Control inputs recognize both DC and AC voltages.

### COMMUNICATION PORTS

Response Time:	<100mSec for metering and control functions
Baud Rate:	300-19200

### ELECTRICAL ENVIRONMENT

- IEEE C37.90-1989 Standard for Relays and Relay Systems Associated with Electric Power Apparatus
- IEC 255-5 Insulation Test for Electrical Relays Impulse and Dielectric Strength (2000Vac at 50/60Hz)

- IEEE C37.90.1-1989 Standard Surge Withstand Capability Tests for Relays and Relay Systems Associated with Electric Power Apparatus
- IEC 255-22-1 1MHz Burst Disturbance Tests for Electrical Disturbance Tests for Measuring Relays and Protection Equipment
- EN 61000-4-4 Electrical Fast Transient/Burst Immunity Test
- EN 61000-4-3 Radiated, Radio-frequency, Electromagnetic Field Immunity Test
- Type tested using a 5-watt, hand-held transceiver in the ranges of 144 and 440MHz with the antenna placed within 6 inches of the relay.
- IEEE C37.90.3 (Jan. 01) Draft Standard Electrostatic Discharge Tests for Protective Relays
- EN 61000-4-2 Electrostatic Discharge Immunity Test

### MECHANICAL ENVIRONMENT

- Operating temperature range: -40°C to 70°C\* (-40°F to 158°F)  
\*LCD Display is inoperative below -20°C.
- Storage temperature range: -40°C to 70°C (-40°F to 158°F)
- Humidity: Qualified to IEC 68-2-38, 1st Edition 1974, Basic Environmental Test Procedures, Part 2: Test Z/AD: Composite Temperature Humidity Cyclic Test
- Vibration: 2g at 10 to 500Hz
- Shock: 15g drop test

### CERTIFICATIONS

UL Recognized, File E97033

CSA Certified, File LR23131

CE: Meets or exceeds the standards required for distribution in the European Community.

Gost R Certified, #POCC US.ME05.B03391

(Patent #5309312: Overcurrent Protection Relay with Communications)

DNP 3.0 IED Certified, Subset Level 2, 6/20/00, by SUBNET Solutions, Inc.

### CASE SIZE

F1: 6.376" (161.9mm) W x 7.25" (184.1mm) H x 8.15" (207mm) D

H1: 10.50" (266.7mm) W x 3.47" (88.1mm) H x 9.10" (231.1mm) D with mounting flanges (8.5" W without mounting flanges)

S1: 6.65" (168.91mm) W x 9.32" (236.73mm) H x 8.38" (212.95mm) D

### SHIPPING WEIGHT

F1: Approx. 11 pounds

H1: Approx. 10 pounds

S1: Approx. 16 pounds

### WARRANTY

7 years

# PERFORMANCE SPECIFICATIONS

## INSTANTANEOUS OVERCURRENT WITH SETTABLE DELAY (50TP, 150TP, 50TN, 150TN, 50TQ, 150TQ)

Pickup: 5A CT: 0.5-150.0A  
 1A CT: 0.1-30.0A  
 PU time with TD=0.000 Sec  
 1¼ cyc for P&N @ 5 x PU  
 2¼ cyc for Q @ 5 x PU  
 Delay time: 0.000 - 60 sec  
 Time Accuracy: ±0.5% or ±¼ cyc for P&N  
 ±0.5% or ±1 cyc for Q

## TIME OVERCURRENT (51P, 51N, 51Q)

Pickup: 5A CT: 0.50-16.0A  
 1A CT: 0.10-3.20A  
 Time Dial: TD=K=0 - 99 for 46 curve  
 TD=0.0 - 9.9 for all other curves

### Time-Current Characteristics:

The following expression describes the inverse time current characteristic for each curve:

$$T_T = \frac{AD}{M^N-C} + BD + K = \text{Time to trip}$$

$$T_R = \frac{RD}{M^2-1} = \text{Time for decaying reset}$$

where D = Time dial, M = Multiple of PU and A, B, C, N, K and R are constants that govern the shape of each curve. The protection engineer can set the constants for the P (programmable) curve to achieve virtually any characteristic.

## BREAKER FAILURE (BF)

Time: 50-999 mSec  
 Dropout: 5A CT: 0.5A  
 1A CT: 0.1A  
 Time Accuracy: ±0.5% or +1¼ cyc/ -¼ cyc

## GENERAL PURPOSE LOGIC TIMERS (62, 162, 262\*, 362\*)

Mode: PU.DO  
 1 Shot, Non-Retrig.  
 1 Shot, Retriggering  
 Integrating  
 Latch  
 T1 and T2 Delay Time: 0.000 - 9999 sec.  
 Time Accuracy: ±0.5% or ±½ cyc

\* Available when style option 1 is V or W.

## RECLOSER (79)

Mode: Power up to close  
 Power up to lockout  
 Reclose Shots: 0 - 4  
 Reclose, Reset, Fail,  
 Max. Cycle Timers: 0.100 - 600 sec.  
 Time Accuracy: ±0.5% or +1¼ cyc /  
 -0 cyc

Curve Type	Constants					
	A	B	C	N	K	R
S1	0.2663	0.03393	1.000	1.2969	0.028	0.5000
S2	0.0286	0.02080	1.000	0.9844	0.028	0.0940
L1	5.6143	2.18592	1.000	1.000	0.028	15.750
L2	2.3955	0.00000	1.000	0.3125	0.028	7.8001
D	0.4797	0.21359	1.000	1.5625	0.028	0.8750
M	0.3022	0.12840	1.000	0.5000	0.028	1.7500
I1	8.9341	0.17966	1.000	2.0938	0.028	9.0000
I2	0.2747	0.1042	1.000	0.4375	0.028	0.8868
V1	5.4678	0.10814	1.000	2.0469	0.028	5.5000
V2	4.4309	0.0991	1.000	1.9531	0.028	5.8231
E1	7.7624	0.02758	1.000	2.0938	0.028	7.7500
E2	4.9883	0.0129	1.000	2.0469	0.028	4.7742
A	0.01414	0.00000	1.000	0.0200	0.028	2.0000
B	1.4636	0.00000	1.000	1.0469	0.028	3.2500
C	8.2506	0.00000	1.000	2.0469	0.028	8.0000
G	12.1212	0.00000	1.000	1.000	0.028	29.000
F	0.0000	1.00000	0.000	0.0000	0.028	1.0000
P	0 to 600	0 to 25	0 to 1	.5 to 2.5	0.028	0 to 30

S1, S2 = CO Short Inv, IAC Short Inv  
 L1, L2 = CO Long Inv, IAC Long Inv  
 D = CO Definite Time  
 M = CO Moderately Inverse  
 I1, I2 = CO Inverse, IAC Inverse  
 V1, V2 = CO Very Inv, IAC Very Inv  
 E1, E2 = CO Ext Inverse, IAC Ext. Inverse

A = IEC Standard Inverse  
 B = IEC Very Inverse  
 C = IEC Extremely Inverse  
 G = IEC Long Time Inverse  
 F = Fixed Time  
 P = Programmable

## CURRENT PICKUP ACCURACY

Phase and Neutral: 5A: 2% or 50mA  
 1A: 2% or 10mA  
 Negative Sequence: 5A: 3% or 75mA  
 1A: 3% or 75mA

## SETTING GROUPS

Setting Groups: 4  
 Control Modes: Automatic: CLP; Dynamic load  
 or unbalance; External:  
 Discrete input logic; Binary  
 Input Logic

## METERING

Current Range: 5A: 0.5 to 15.0  
 1A: 0.1 to 3.0  
 Current Accuracy: ±1%

## DEMANDS (IA, IB, IC, IN, IQ)

Demand Interval: 1 - 60 min.  
 Demand Mode: Thermal

## BREAKER MONITORING

Duty Mode: I or I<sup>2</sup>  
 Duty Alarm Range: 0-100%  
 Op Counter Alarm Range: 0-99999  
 Trip Time Alarm Range: 20-1000 mSec

# ORDERING

## SAMPLE STYLE NUMBER

The style number identification chart below defines the electrical characteristics and operation features included in the BE1-851 relay. For example, if the style number were **BE1-851 H5N1H0U**, the device would have the following:

- BE1-851** Overcurrent Protection System
- (H)** - Three Phase, Neutral, and Negative Sequence Protection
  - (5)** - 5 Amp Nominal System with 5 Amp Independent Ground Input
  - (N)** - Not applicable
  - (1)** - 48/125 Vac/dc Power Supply
  - (H)** - Half Rack Drawout Case
  - (0)** - ASCII Communications
  - (U)** - Battery backup for Real Time Clock

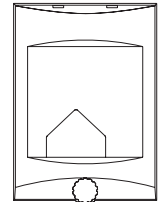
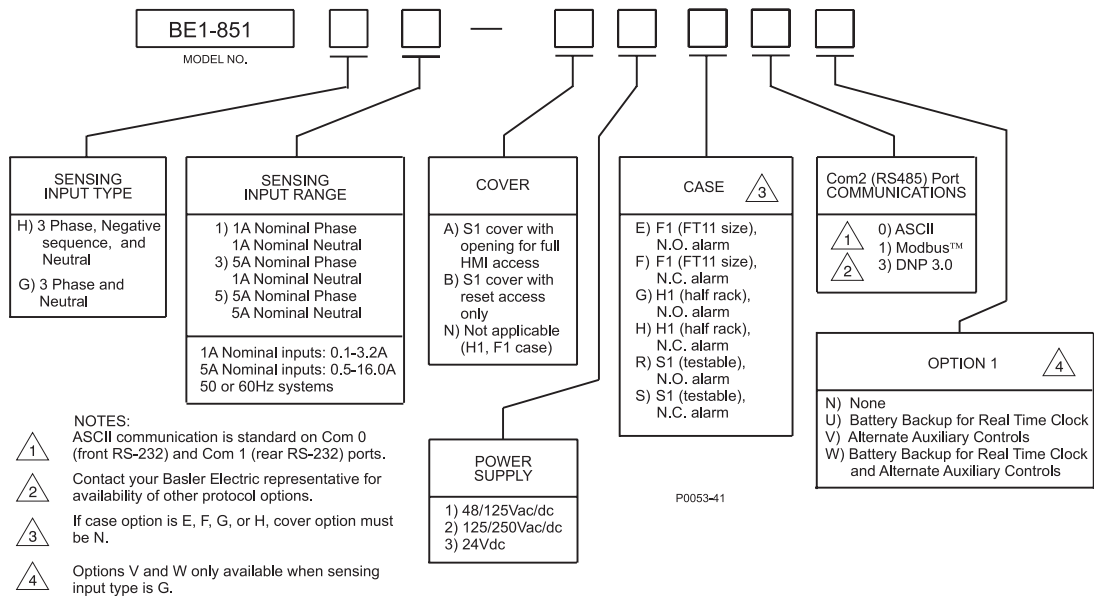

**Figure 7A**  
Cover option A.

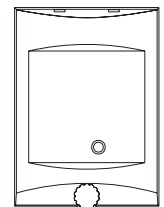
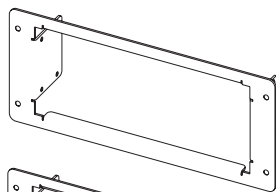

**Figure 7B**  
Cover option B.

## STANDARD ACCESSORIES

- 9334818100 Battery Backup Replacement kit (if "U" is chosen for Option 1).
- 9108551021 Adapter plate to mount an S1 case in a GE S2 or Westinghouse FT-21 cutout.
- 9108551022 Adapter plate to mount an S1 case in a Westinghouse FT-32 cutout.

9289900017  
Escutcheon plate to panel mount one H1 relay.



9289900016  
Escutcheon plate to panel mount two dovetailed H1 relays.

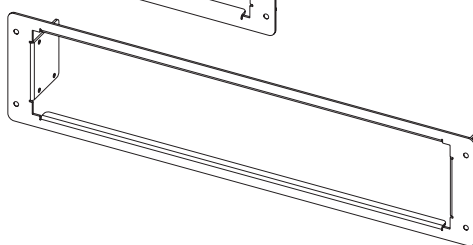

9289929100  
Adapter bracket with cutout for ABB FT test switch, to mount a single H1 case in a 19" rack.

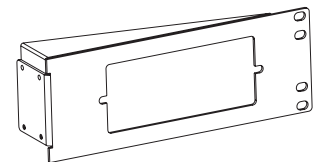

9289924100  
Adapter bracket to mount single H1 case in 19" rack.

